



US007916309B2

(12) **United States Patent**  
**Gharib et al.**

(10) **Patent No.:** **US 7,916,309 B2**  
(45) **Date of Patent:** **Mar. 29, 2011**

(54) **SINGLE-LENS, SINGLE-APERTURE,  
SINGLE-SENSOR 3-D IMAGING DEVICE**

2007/0008312 A1 1/2007 Zhou et al.  
2007/0103460 A1 5/2007 Zhang et al.  
2007/0188769 A1 8/2007 Rohaly et al.

(75) Inventors: **Morteza Gharib**, San Marino, CA (US);  
**Emilio Graff**, Altadena, CA (US);  
**Francisco Pereira**, Rome (IT)

**FOREIGN PATENT DOCUMENTS**

WO WO2007056768 5/2007  
WO WO 2008/091691 7/2008

(73) Assignee: **California Institute of Technology**,  
Pasadena, CA (US)

**OTHER PUBLICATIONS**

(\*) Notice: Subject to any disclaimer, the term of this  
patent is extended or adjusted under 35  
U.S.C. 154(b) by 325 days.

PCT International Preliminary Report on Patentability.  
Lowe, David G, "Three-Dimensional Object Recognition from  
Single Two-Dimensional Images," Artificial Intelligence, 31, 3 (Mar.  
1987), pp. 355-395. Wu, M.; Roberts, J. W.; and Buckley, M., "Three-  
dimensional fluorescent particle tracking at micron-scale using a  
single camera," Experiments in Fluids, 2005, 38, 461-465.  
Willert, C.E.; and Gharib, M., "Three-dimensional particle imaging  
with a single camera," Experiments in Fluids, 1992, 12, 353-358.  
PCT International Search Report and the Written Opinion of the  
International Searching Authority.

(21) Appl. No.: **12/150,237**

(22) Filed: **Apr. 23, 2008**

(65) **Prior Publication Data**

US 2008/0259354 A1 Oct. 23, 2008

*Primary Examiner* — Gregory J Toatley  
*Assistant Examiner* — Amanda H Merlino

(74) *Attorney, Agent, or Firm* — Law Office of Scott C.  
Harris, Inc.

**Related U.S. Application Data**

(60) Provisional application No. 60/925,918, filed on Apr.  
23, 2007, provisional application No. 60/926,010,  
filed on Apr. 23, 2007, provisional application No.  
60/926,023, filed on Apr. 23, 2007.

(57) **ABSTRACT**

A device and method for three-dimensional (3-D) imaging  
using a defocusing technique is disclosed. The device com-  
prises a lens having a substantially oblong aperture, a sensor  
operable for capturing light transmitted from an object  
through the lens and the substantially oblong aperture, and a  
processor communicatively connected with the sensor for  
processing the sensor information and producing a 3-D image  
of the object. The aperture may have an asymmetrical shape  
for distinguishing objects in front of versus in back of the  
focal plane. The aperture may also be rotatable, where the  
orientation of the observed pattern relative to the oblong  
aperture is varied with time thereby removing the ambiguity  
generated by image overlap. The disclosed device further  
comprises a light projection system configured to project a  
predetermined pattern onto a surface of the desired object  
thereby allowing for mapping of unmarked surfaces in three  
dimensions.

(51) **Int. Cl.**

**G01B 11/24** (2006.01)

(52) **U.S. Cl.** ..... **356/601**

(58) **Field of Classification Search** ..... None  
See application file for complete search history.

(56) **References Cited**

**U.S. PATENT DOCUMENTS**

6,229,913 B1 5/2001 Nayar et al.  
6,955,656 B2 10/2005 Bergheim et al.  
7,006,132 B2 2/2006 Pereira et al.  
2004/0155975 A1 8/2004 Hart et al.  
2006/0092314 A1 5/2006 Silverstein et al.  
2006/0209193 A1 9/2006 Pereira et al.

**18 Claims, 28 Drawing Sheets**

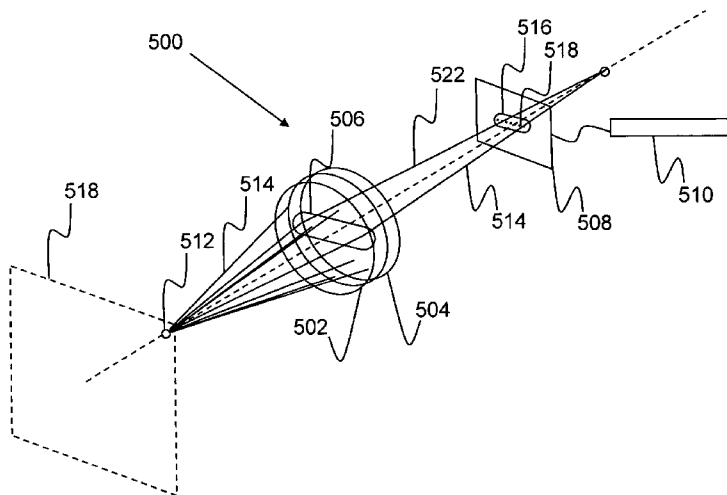

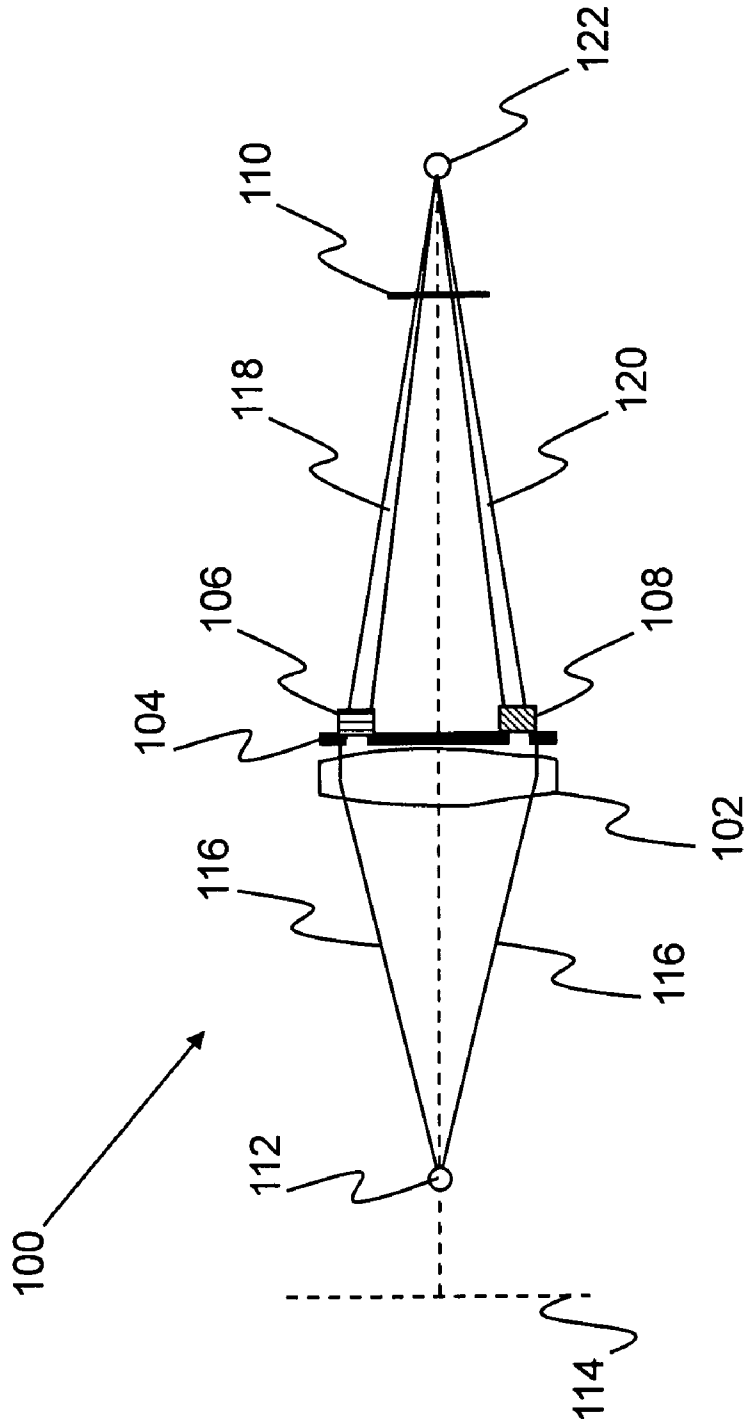

FIG. 1A

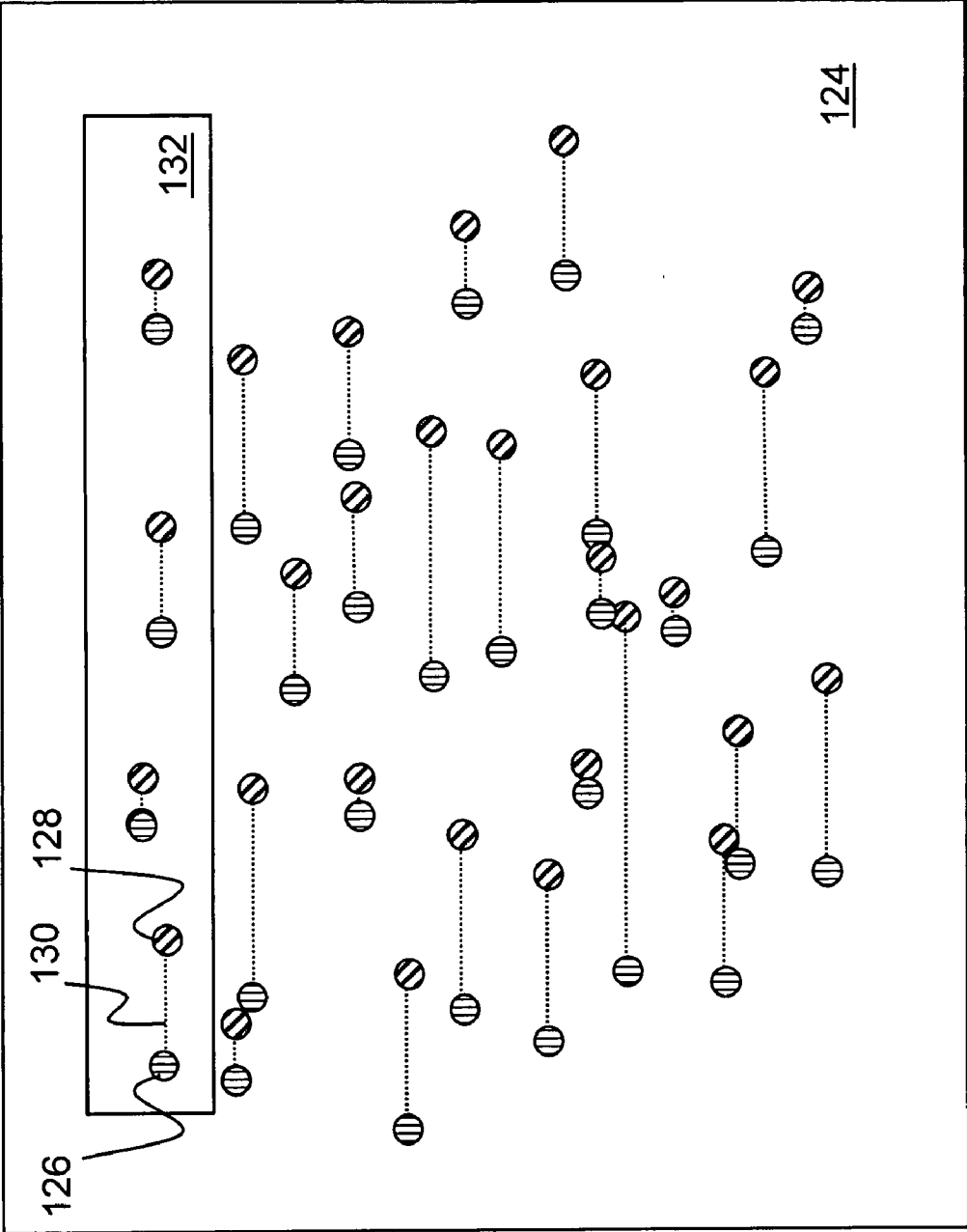

FIG. 1B

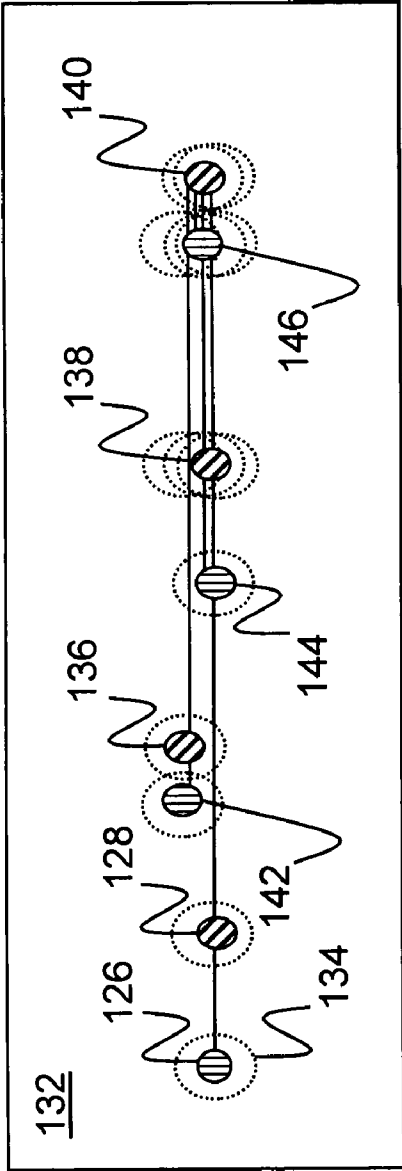

FIG. 1C

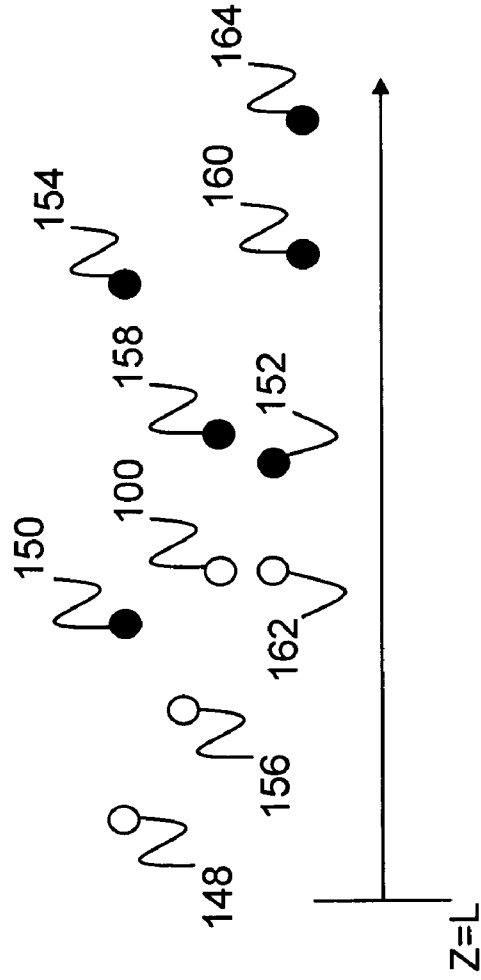

FIG. 1D

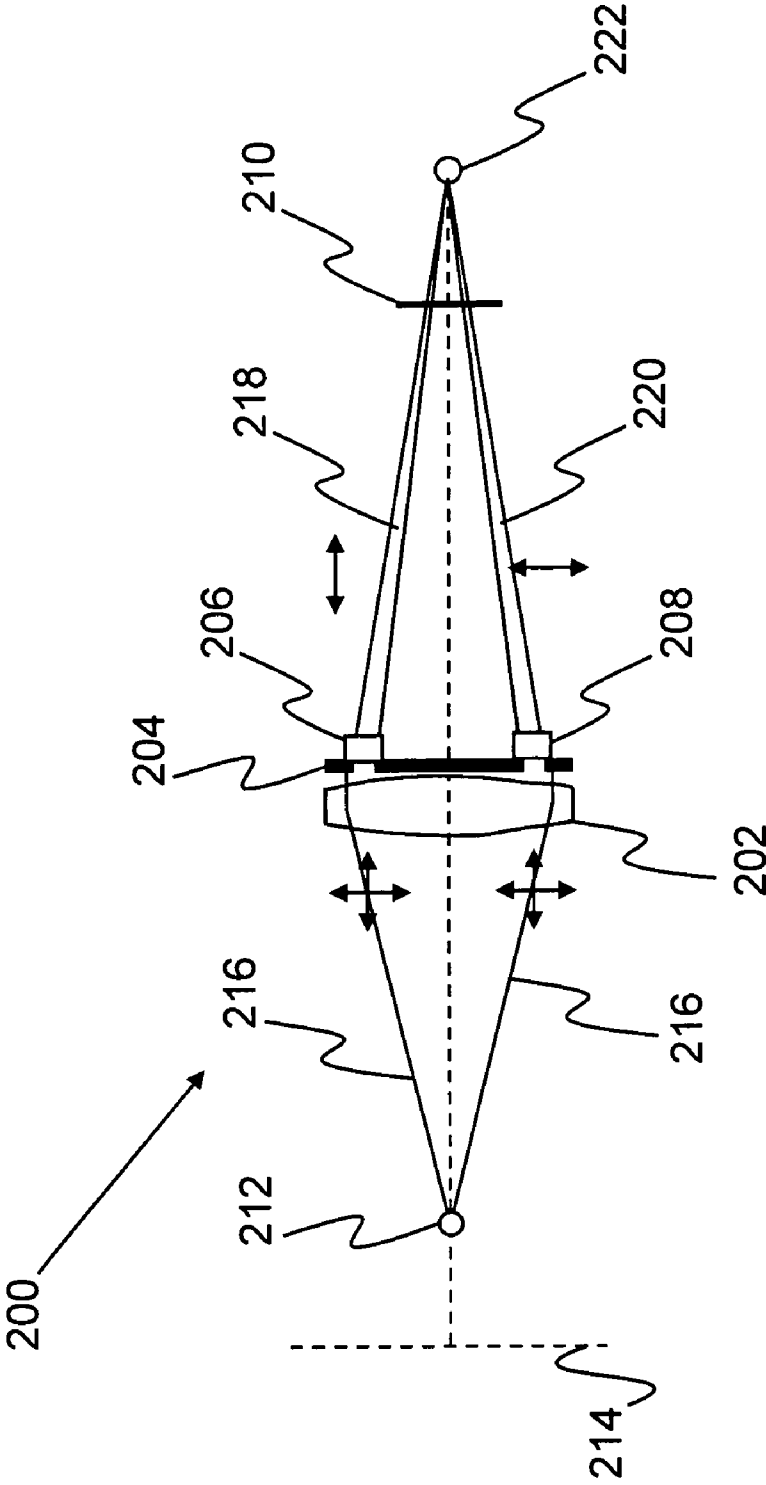

FIG. 2A

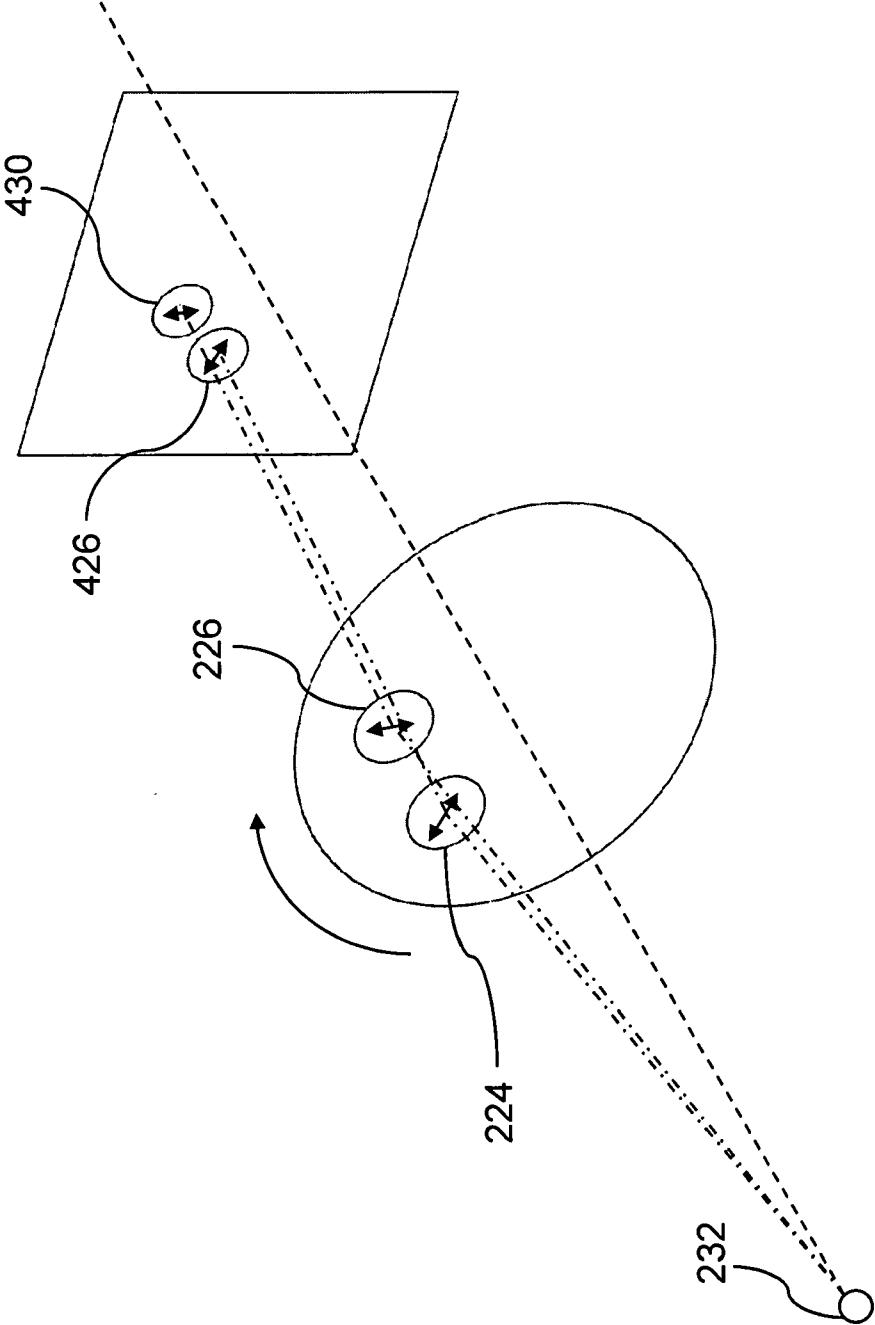

FIG. 2B

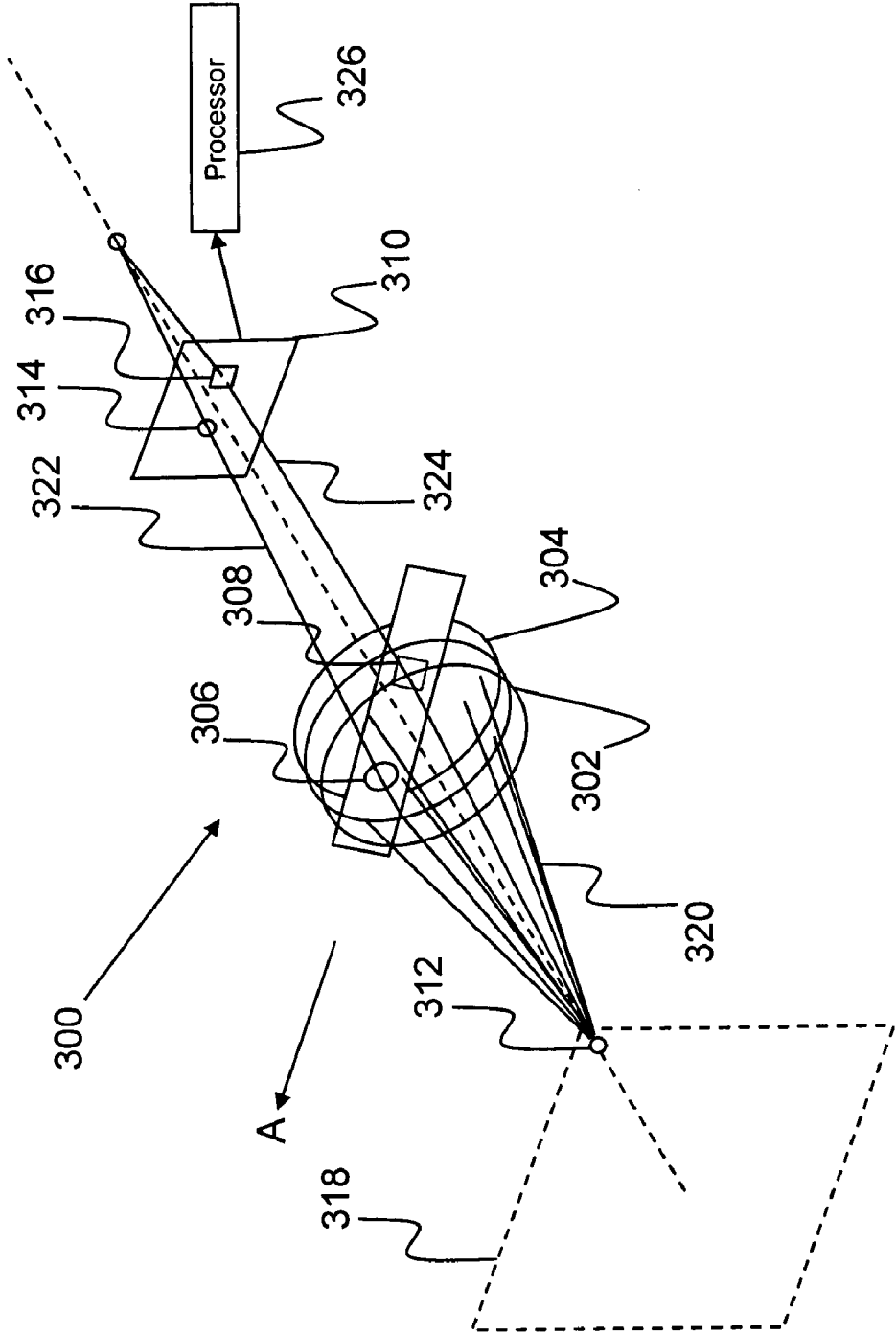

FIG. 3A

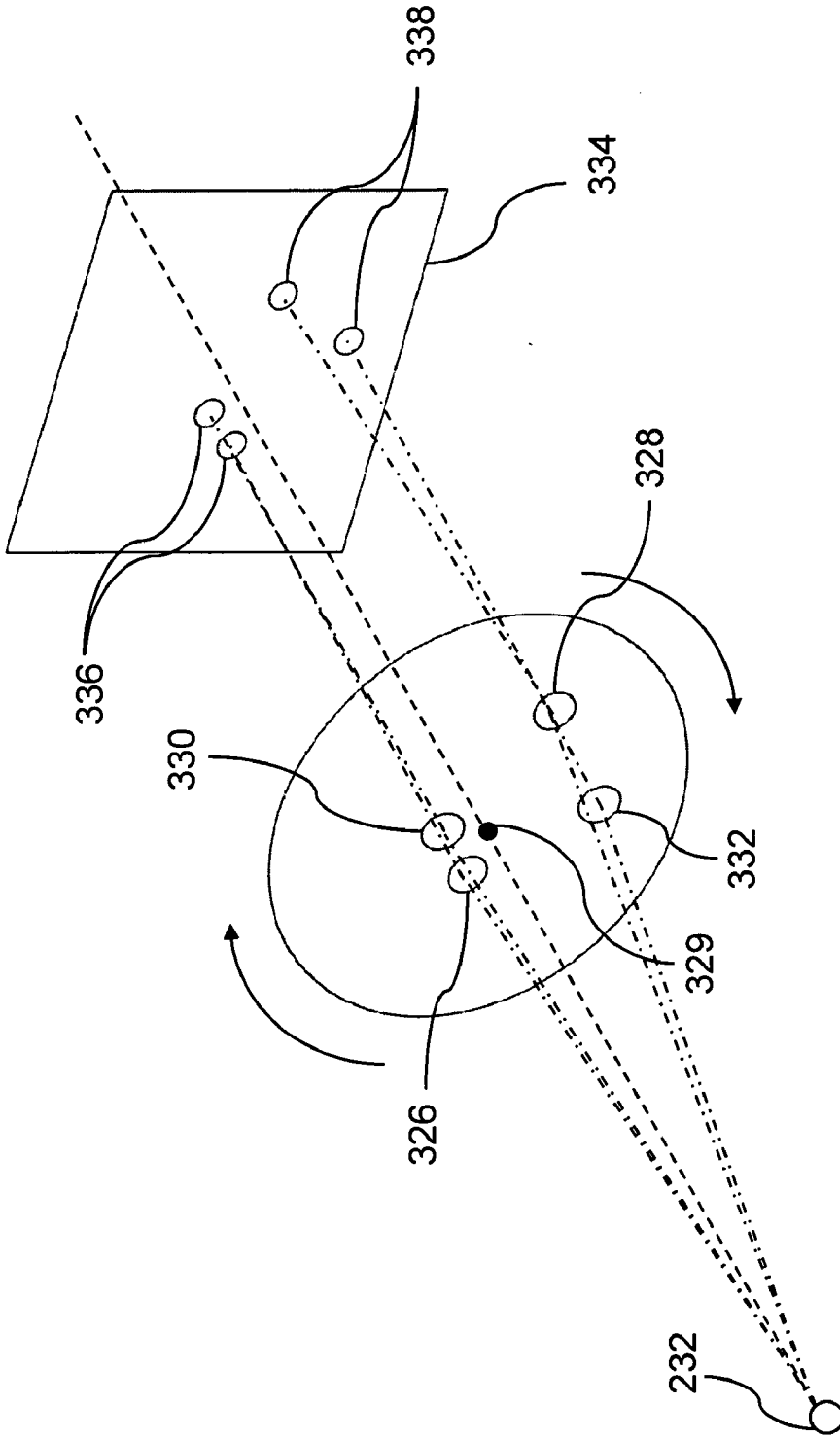

FIG. 3B



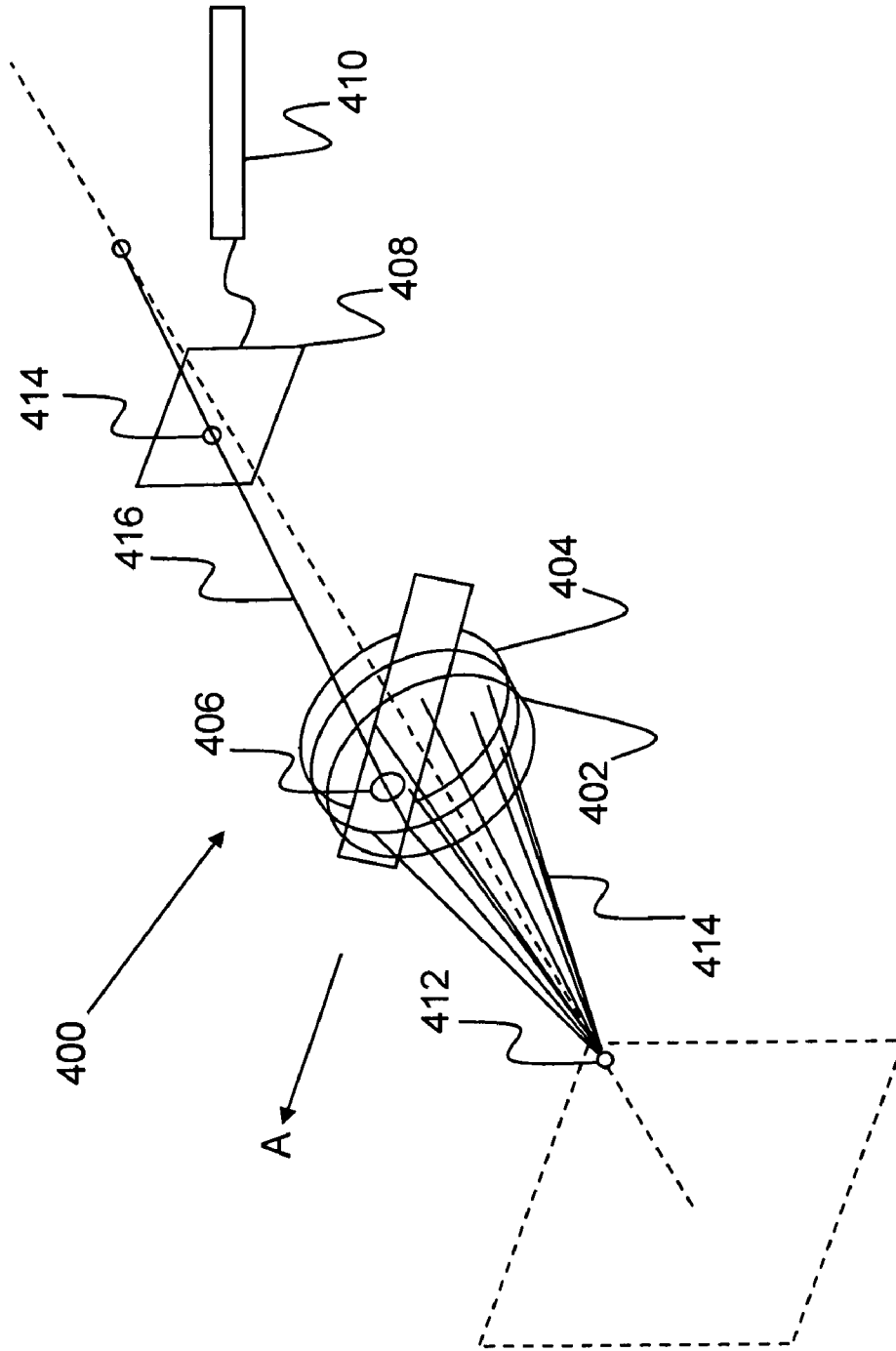

FIG. 4A

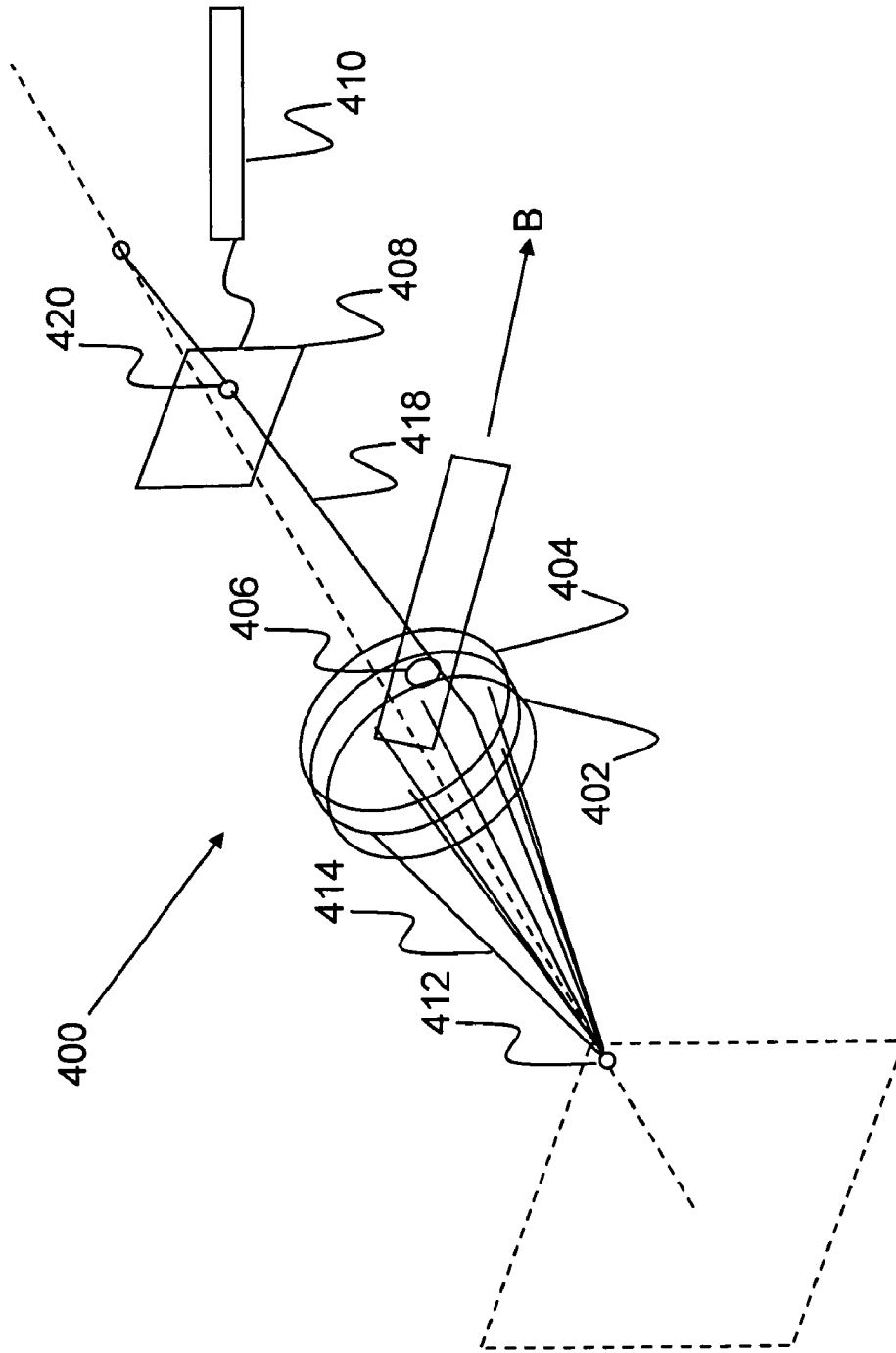

FIG. 4B

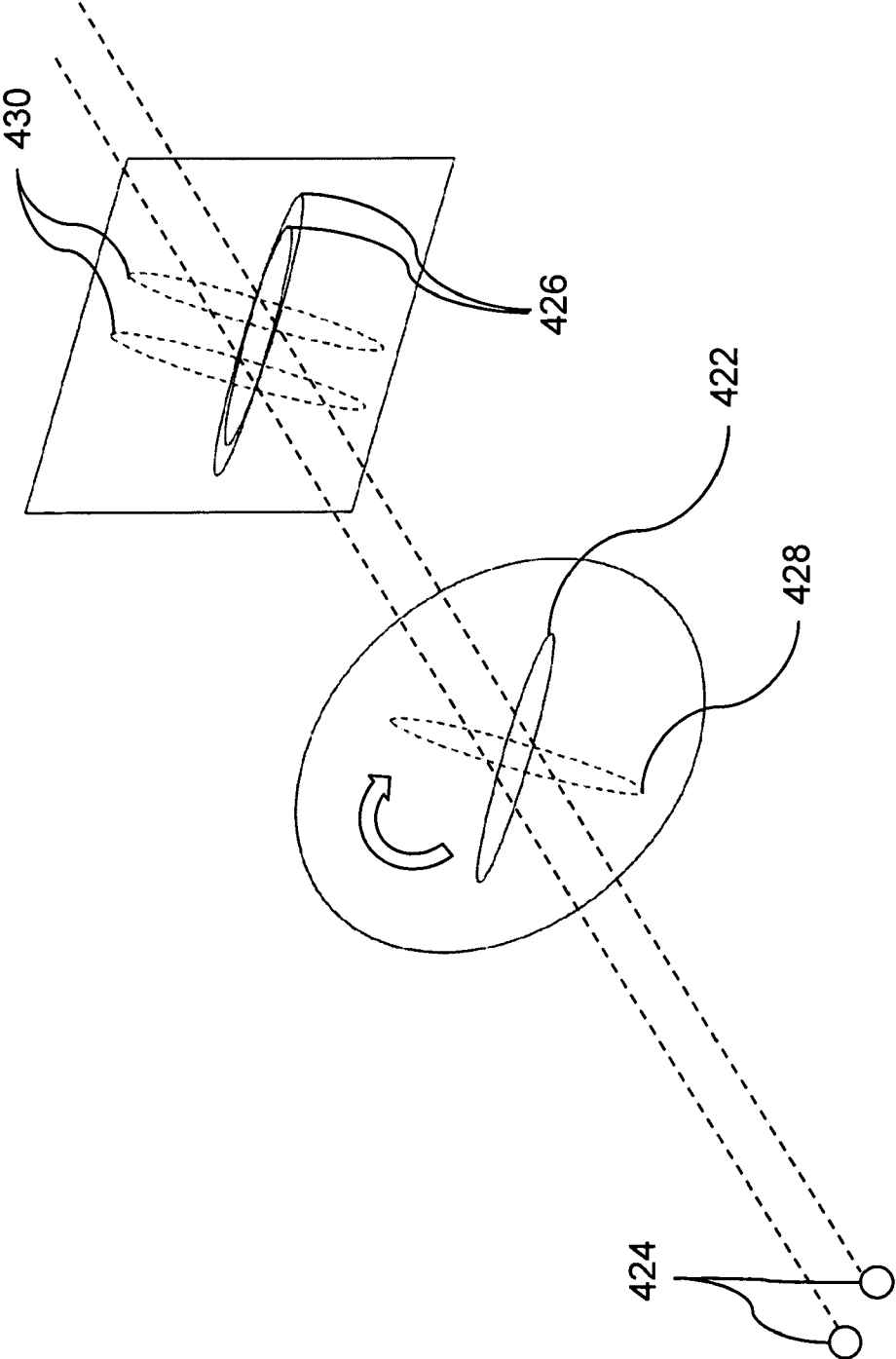

FIG. 4C

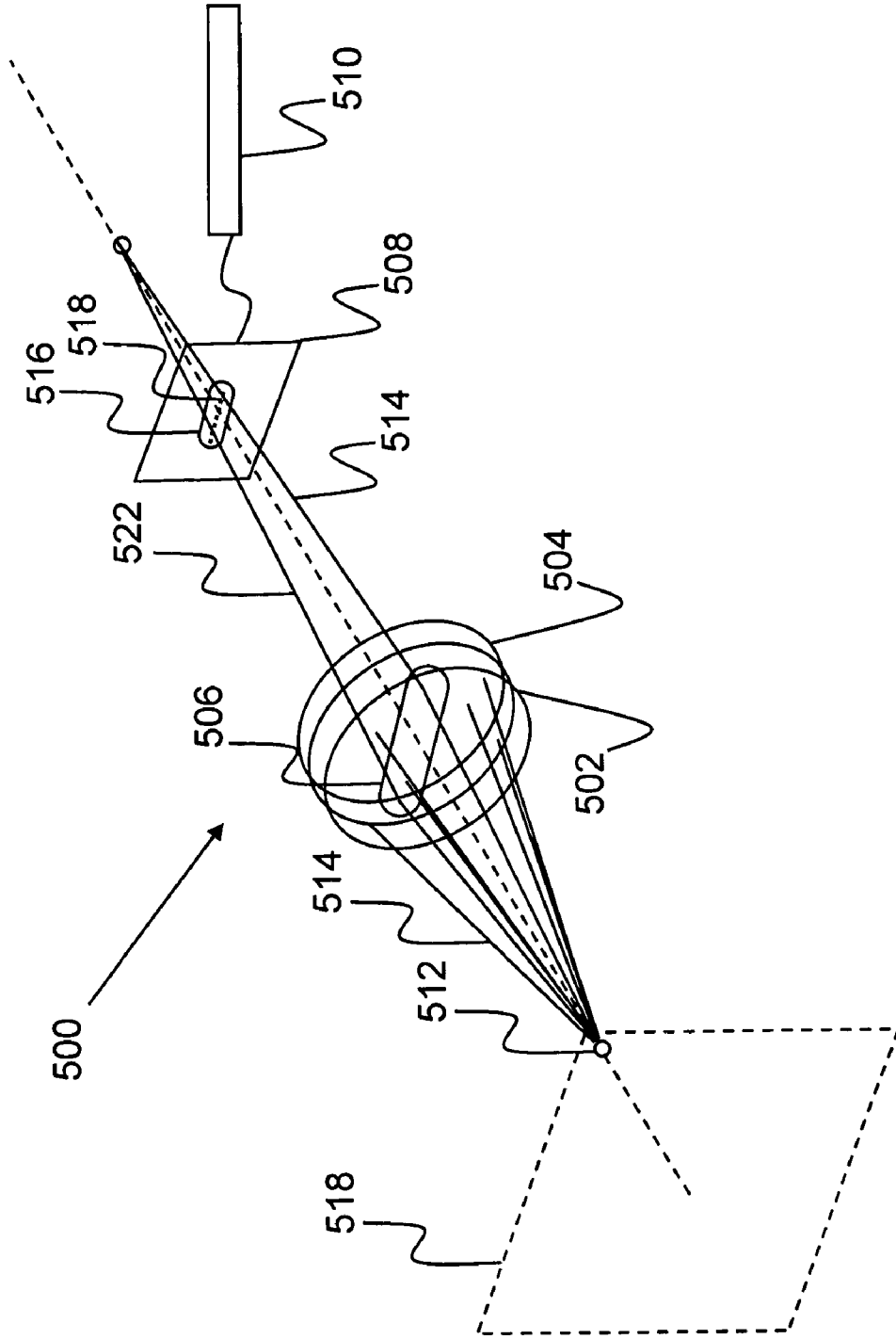

FIG. 5A

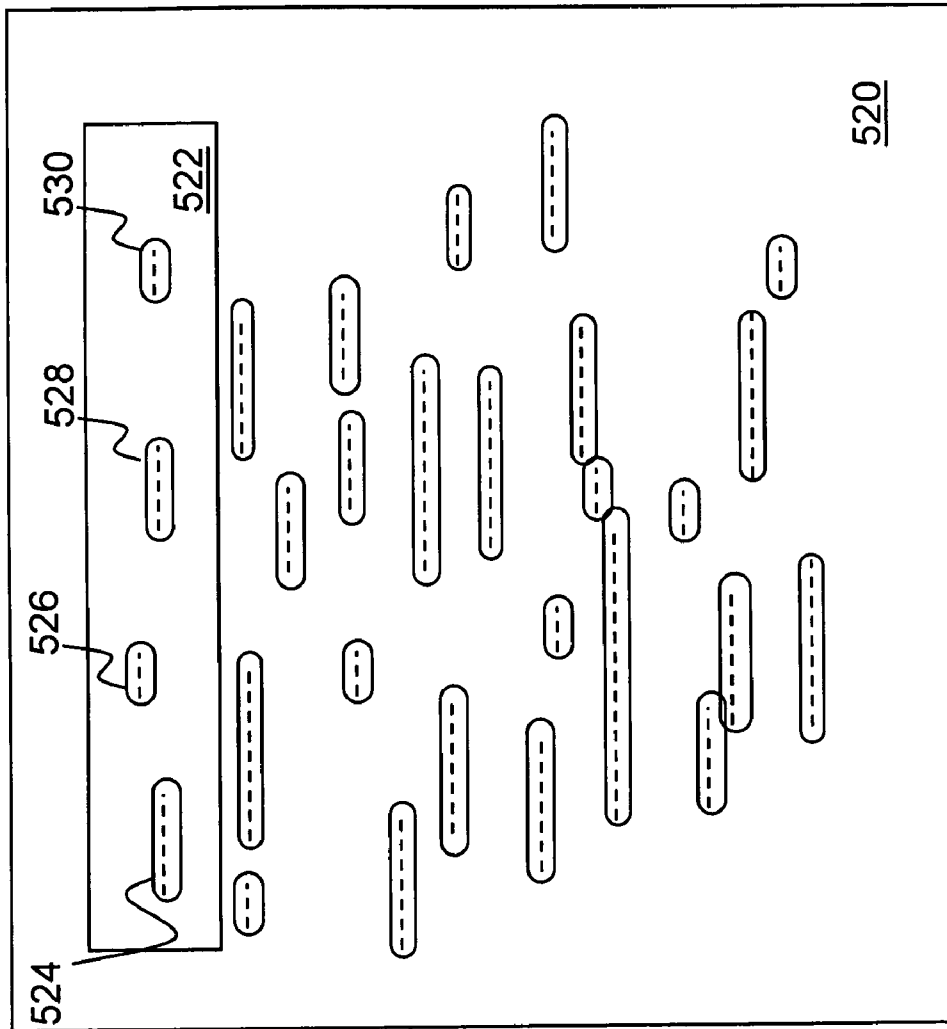

FIG. 5B

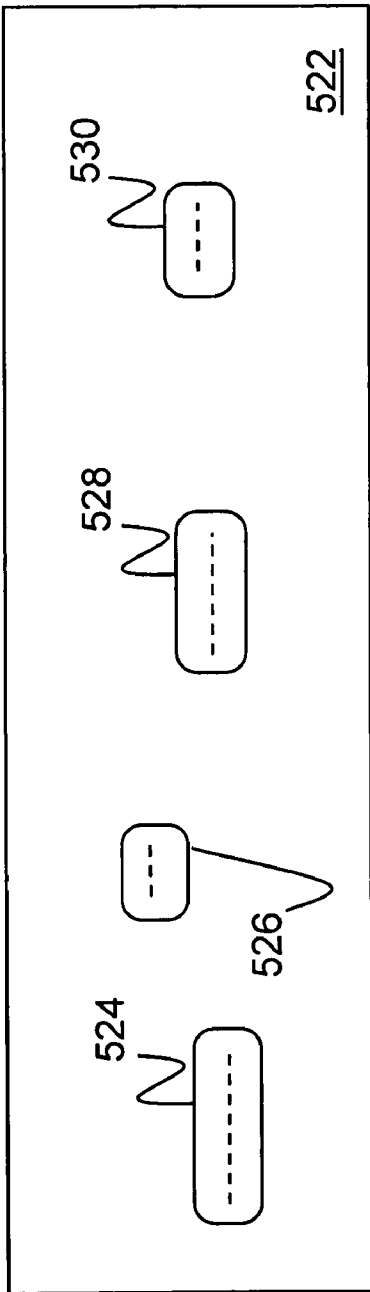

FIG. 5C

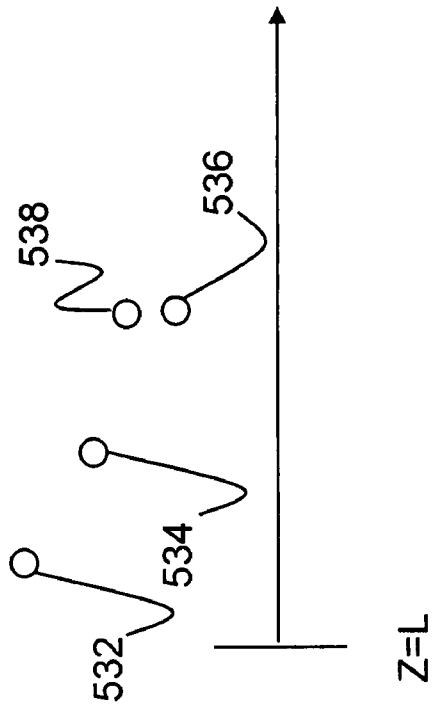

FIG. 5D



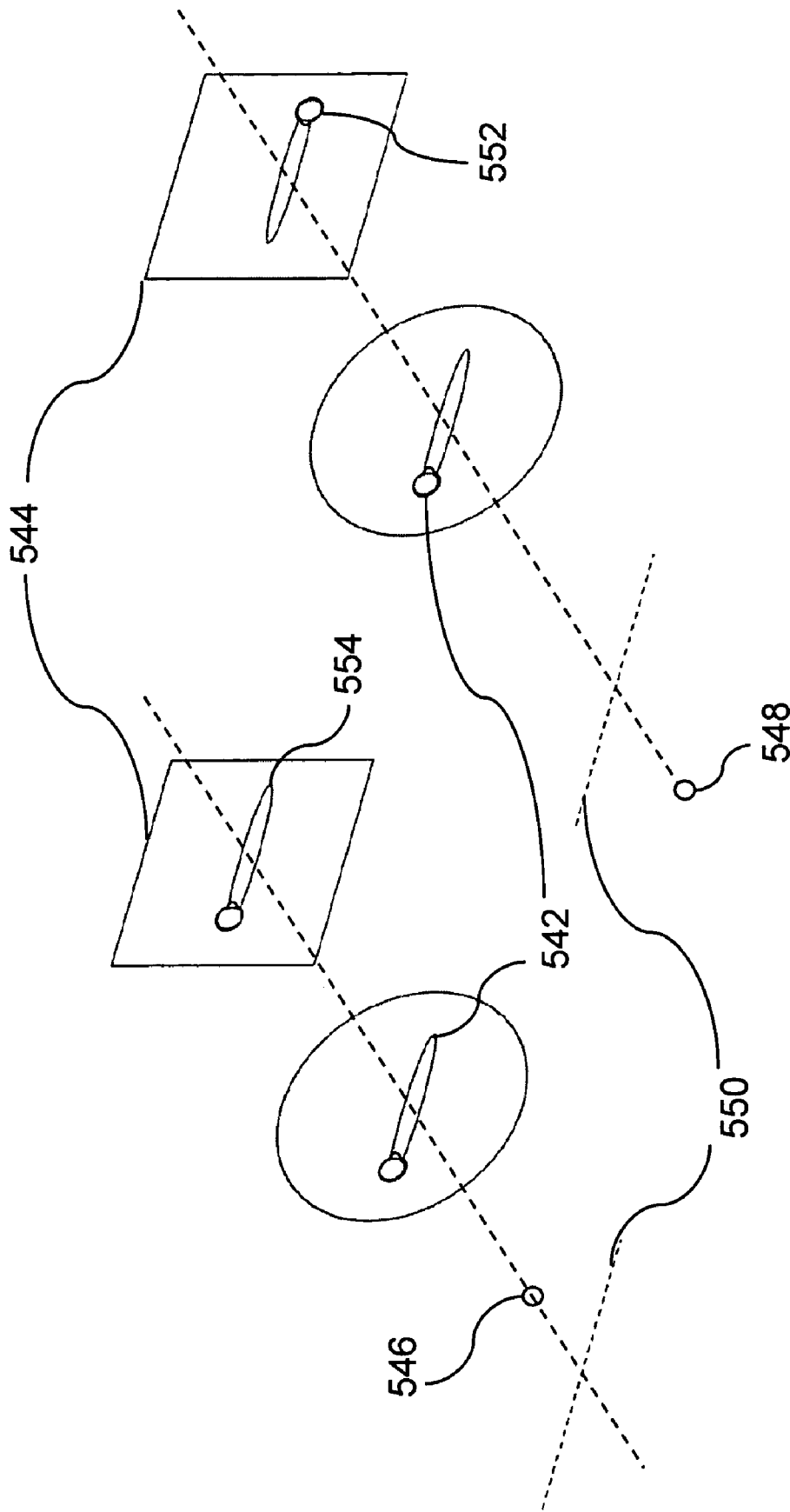

FIG. 5F



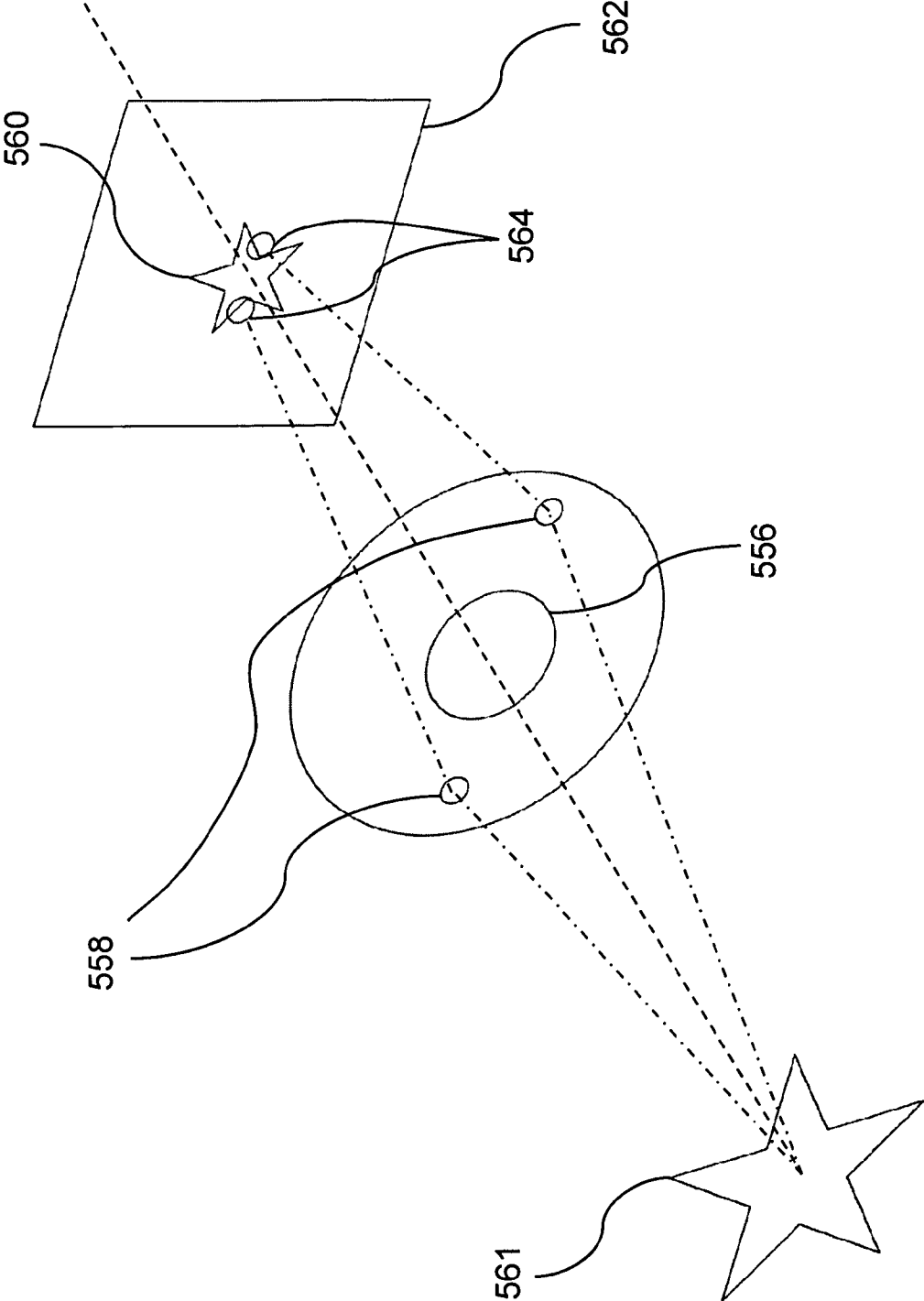

FIG. 5G

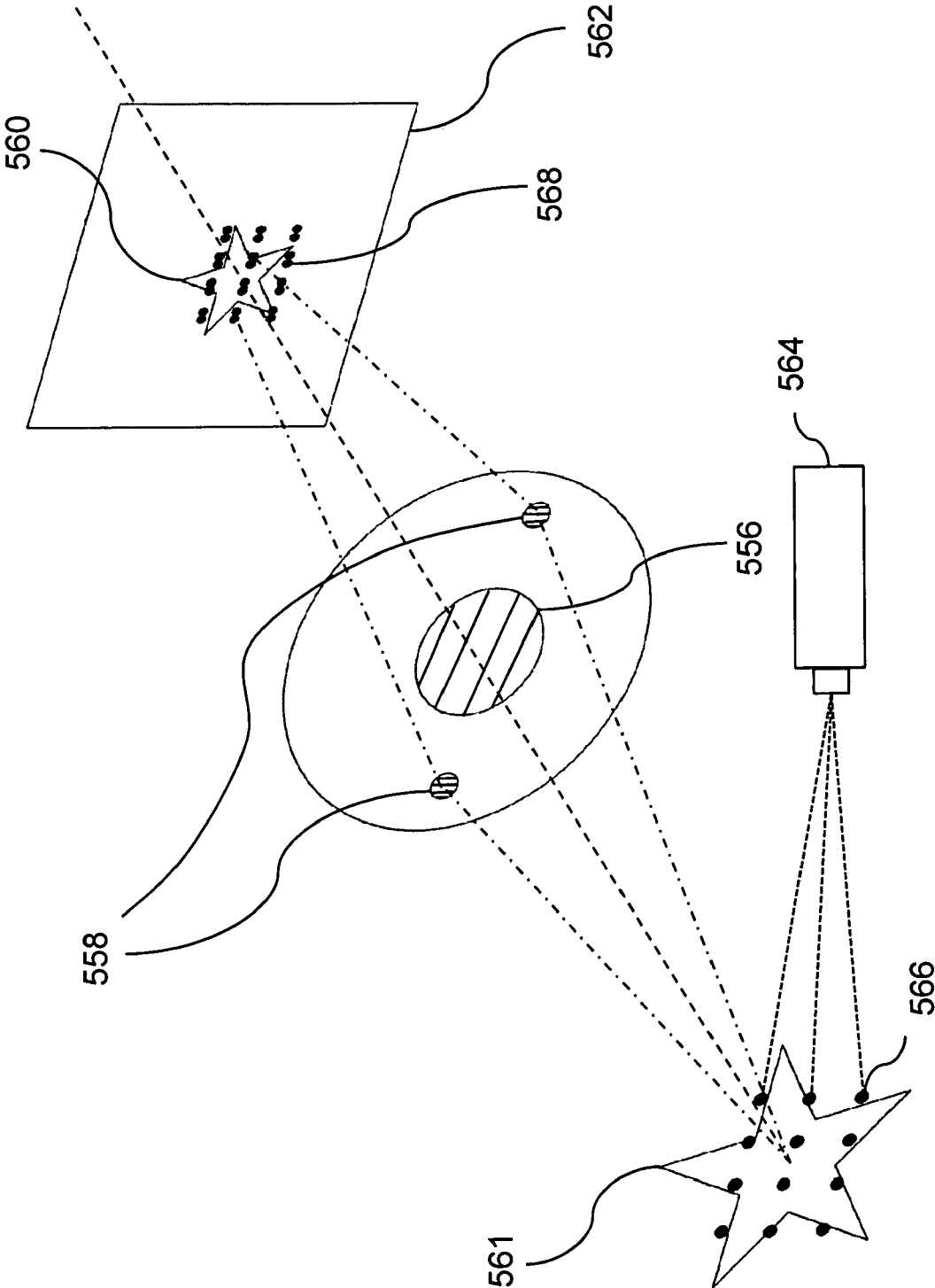

FIG. 5H

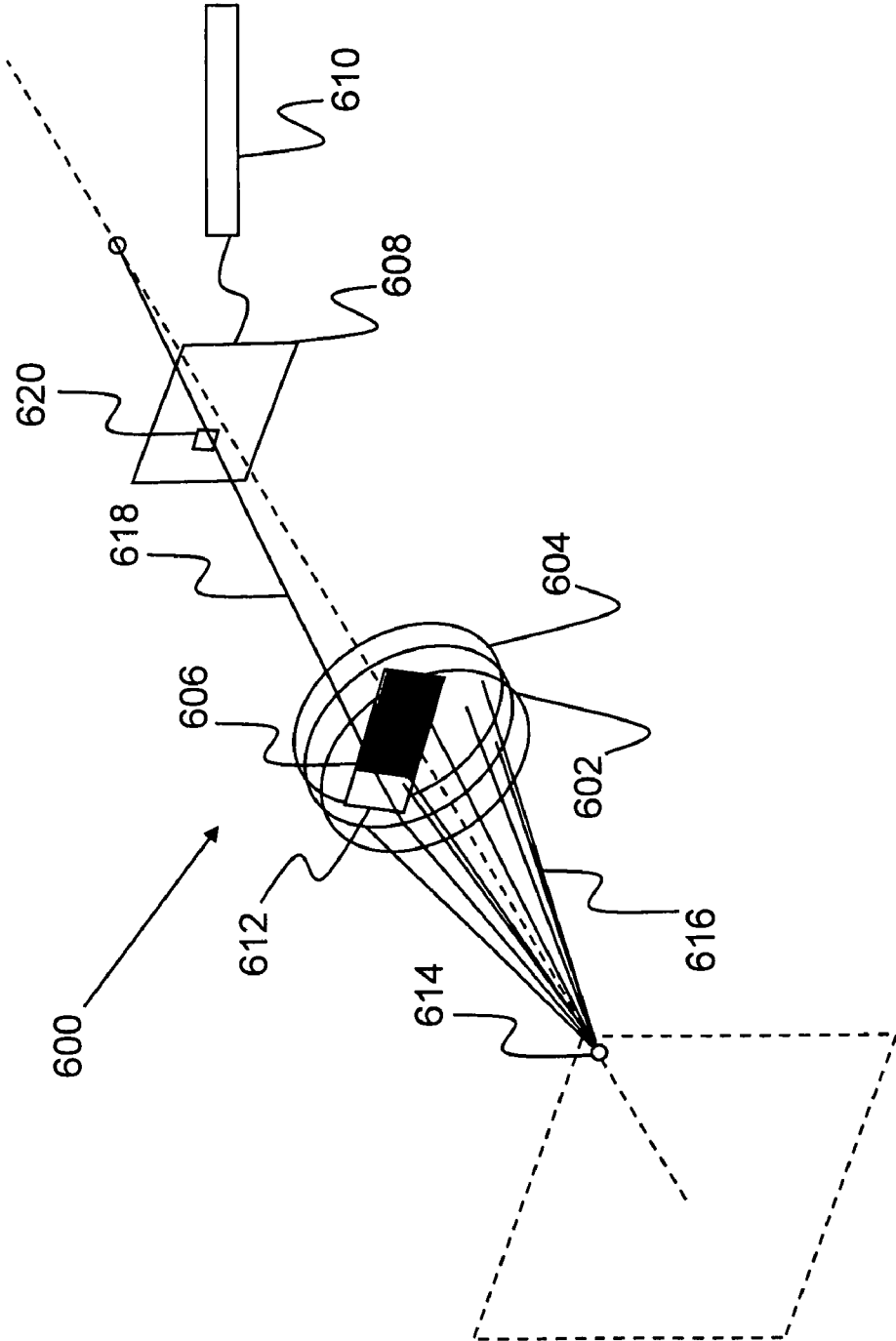

FIG. 6A

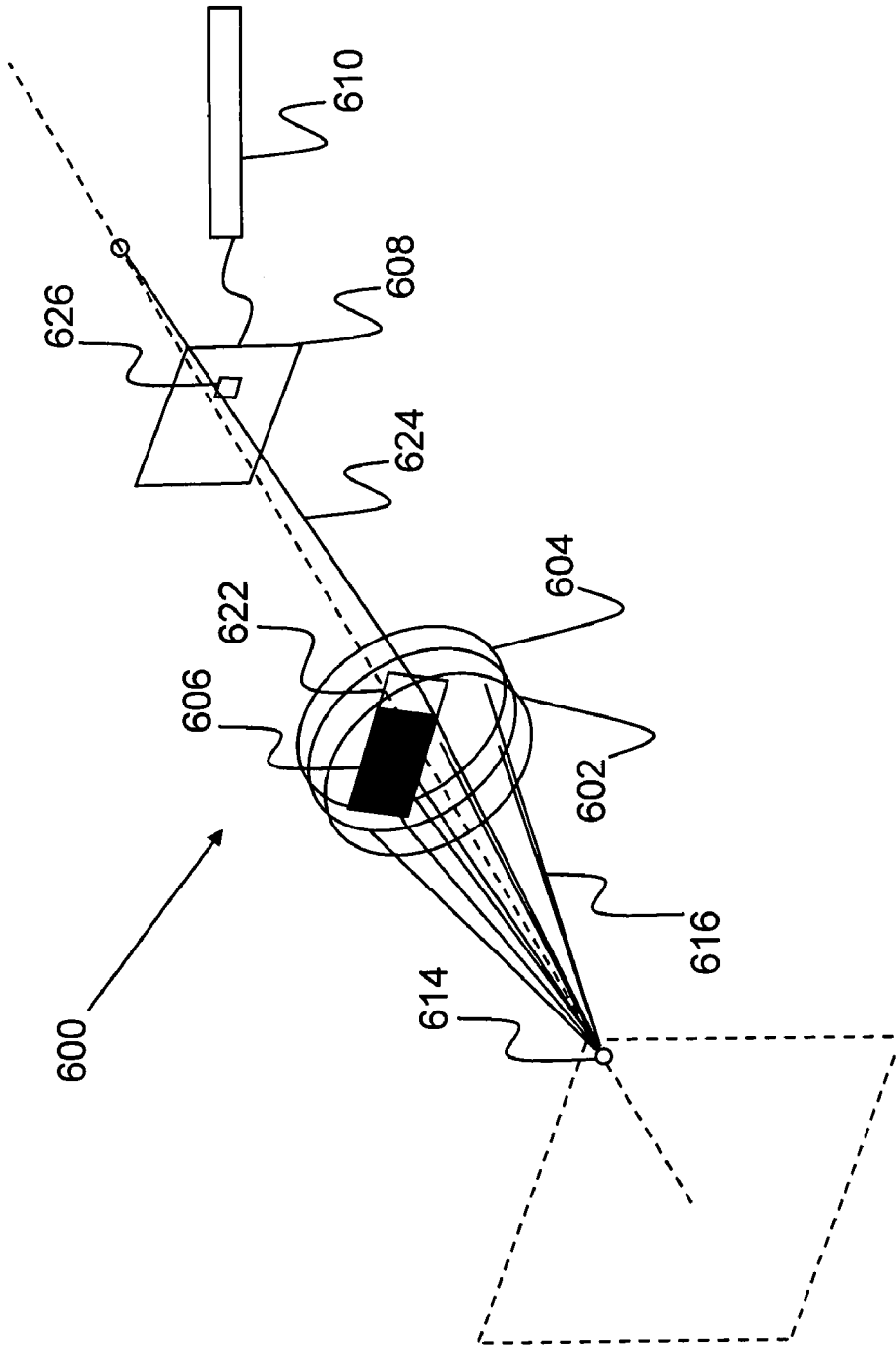

FIG. 6B

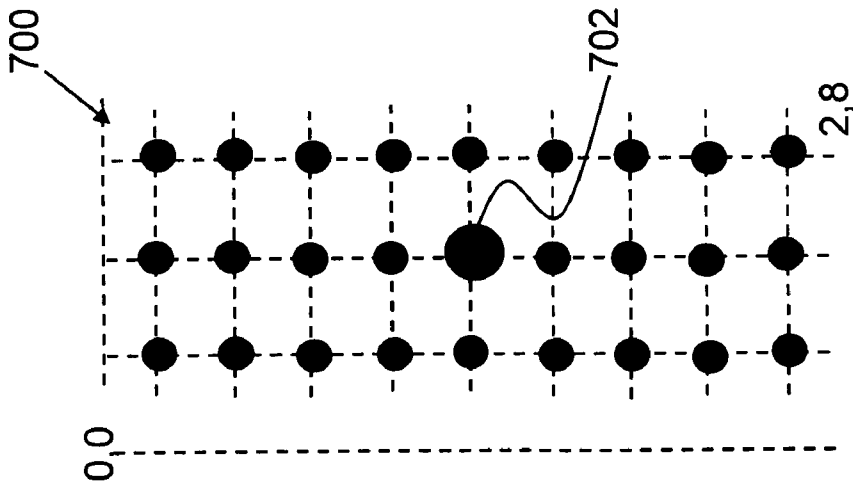

FIG. 7A

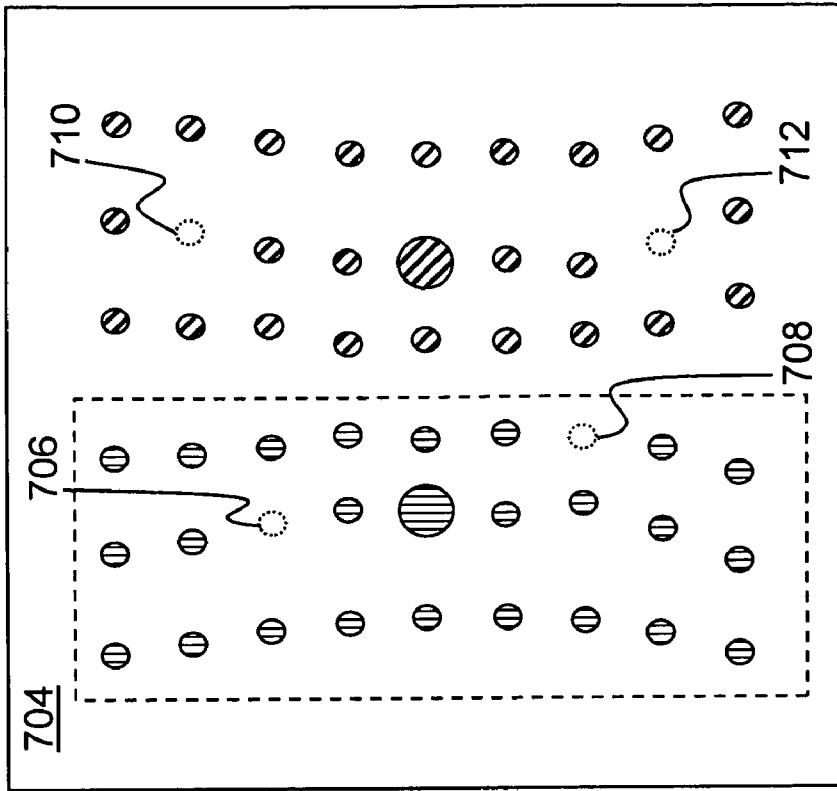

FIG. 7B

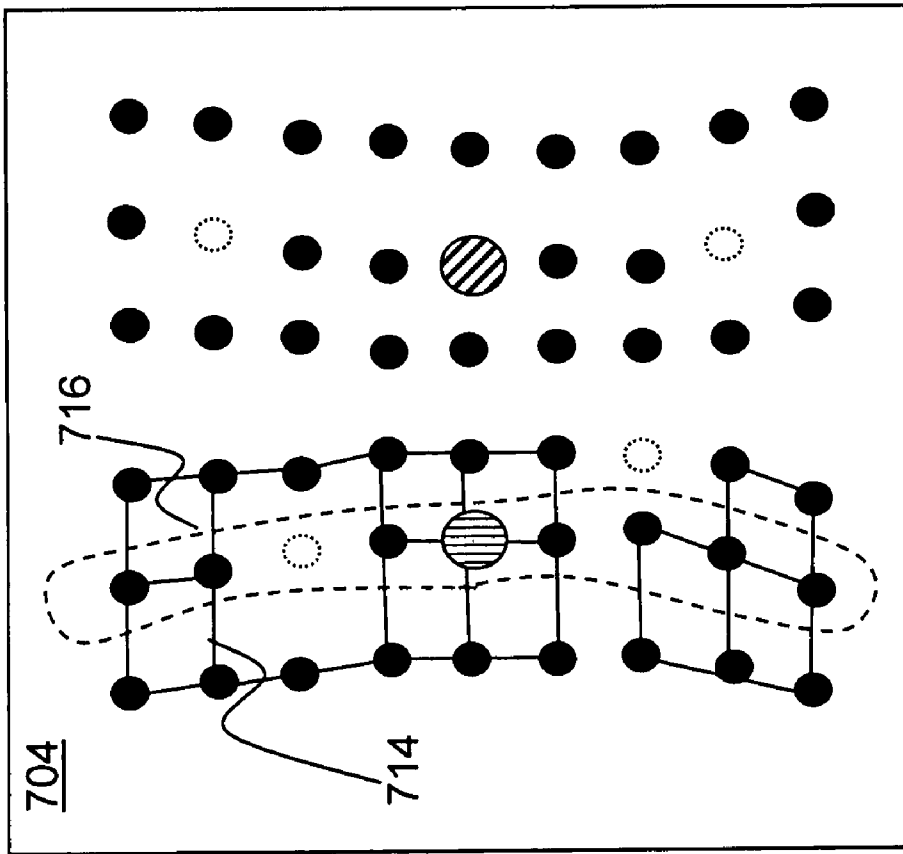

FIG. 7C

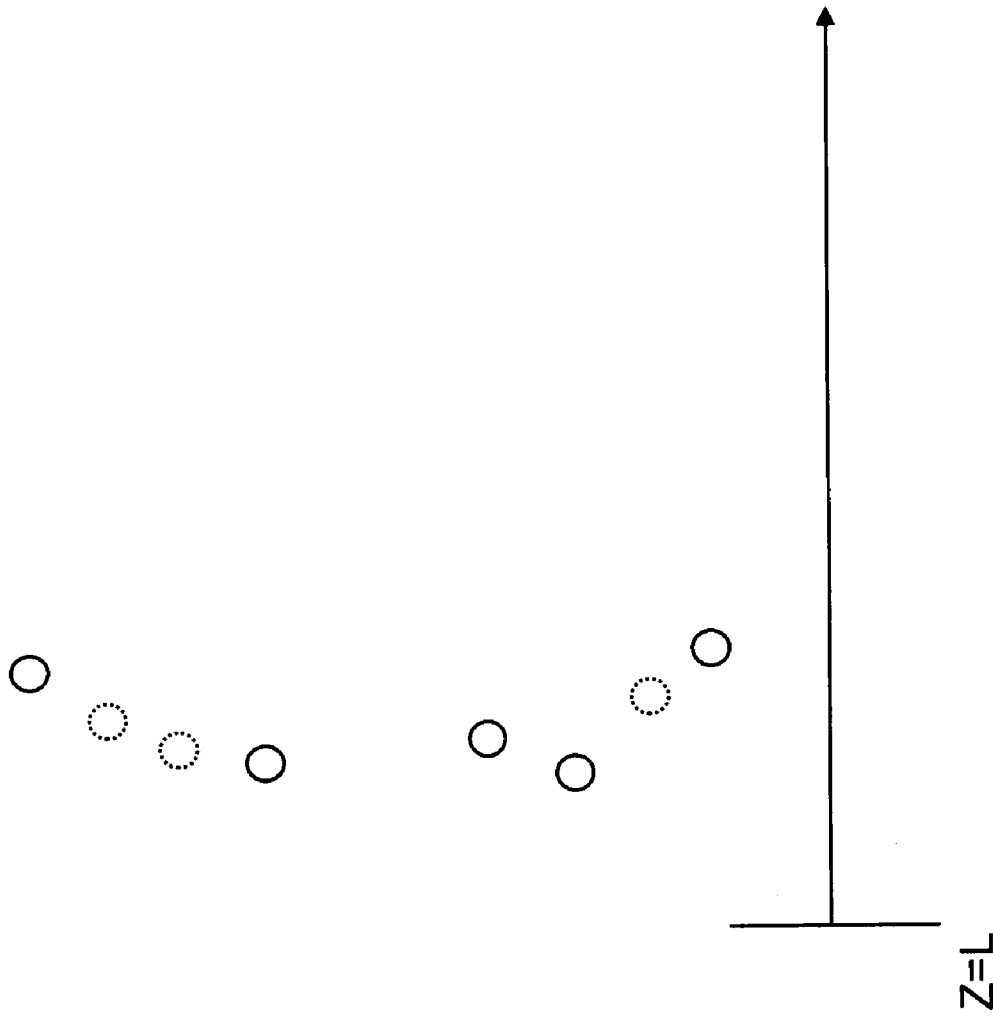

FIG. 7D

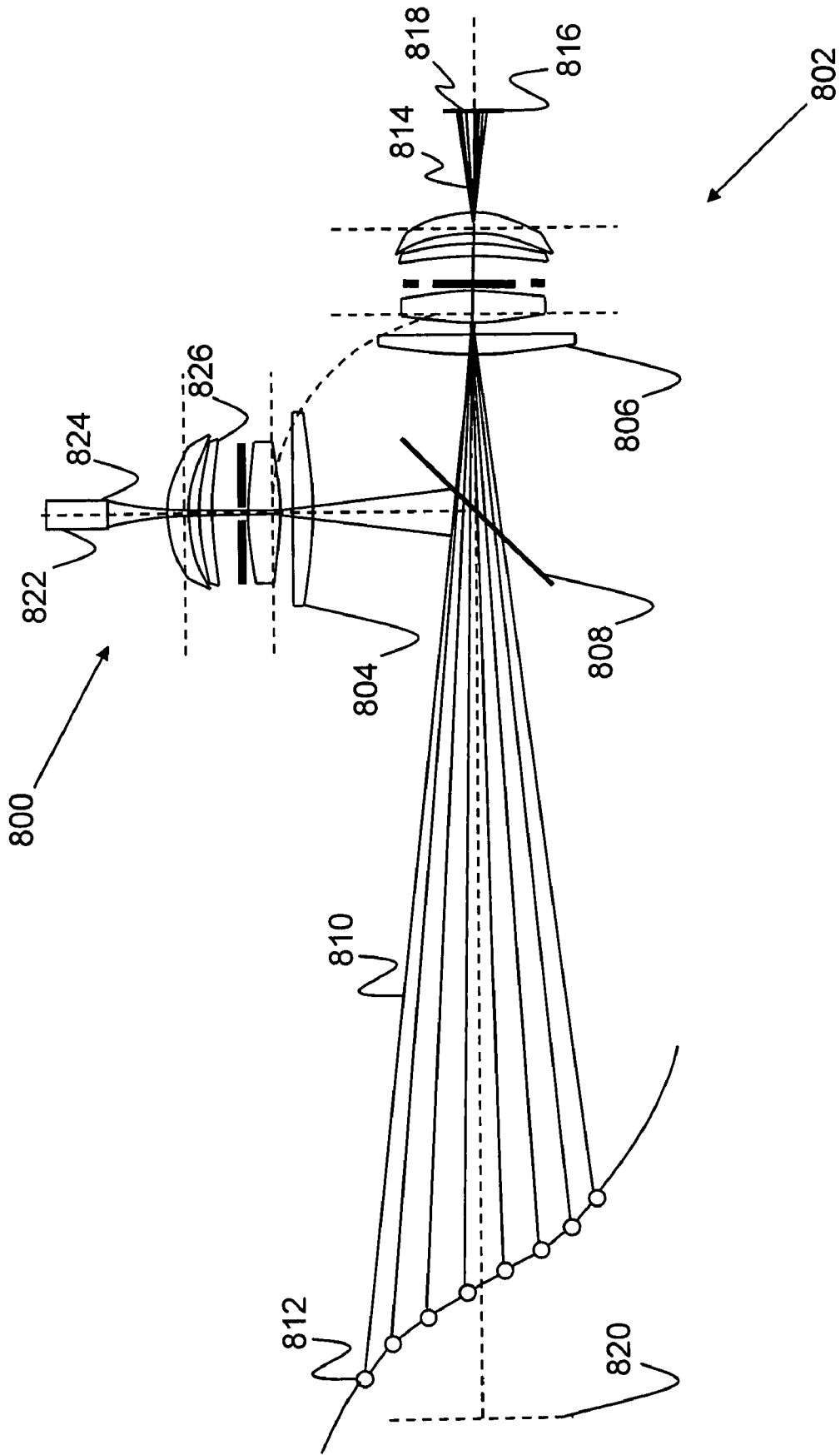

FIG. 8A



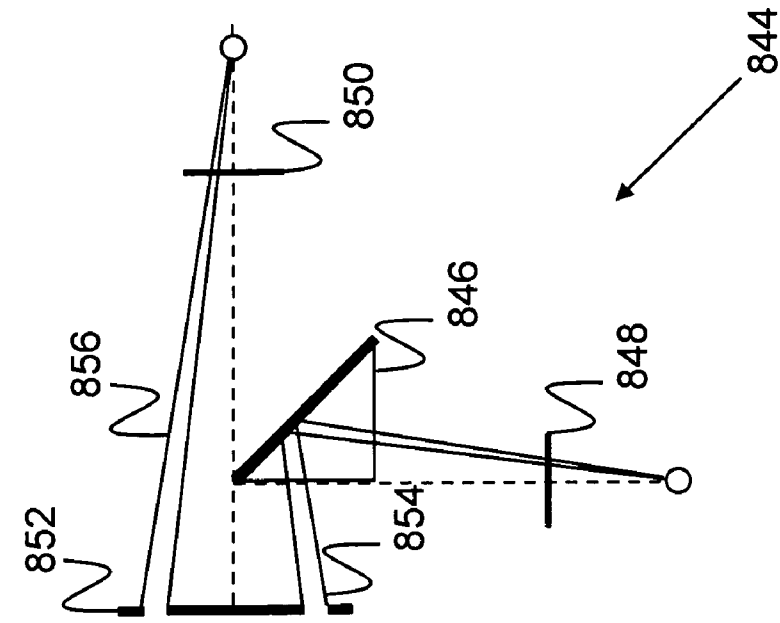

FIG. 8C

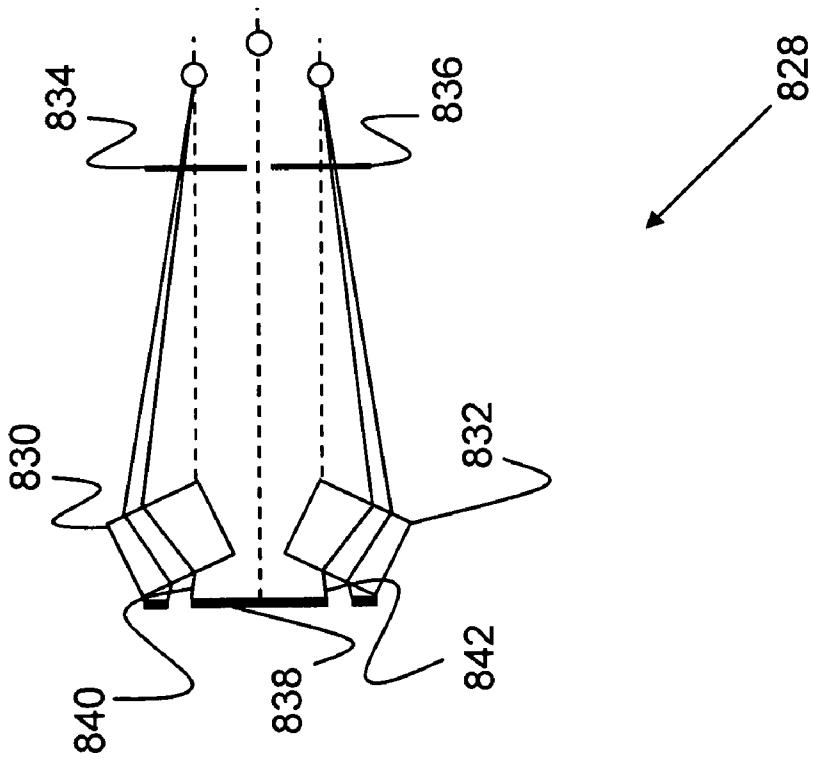

FIG. 8B

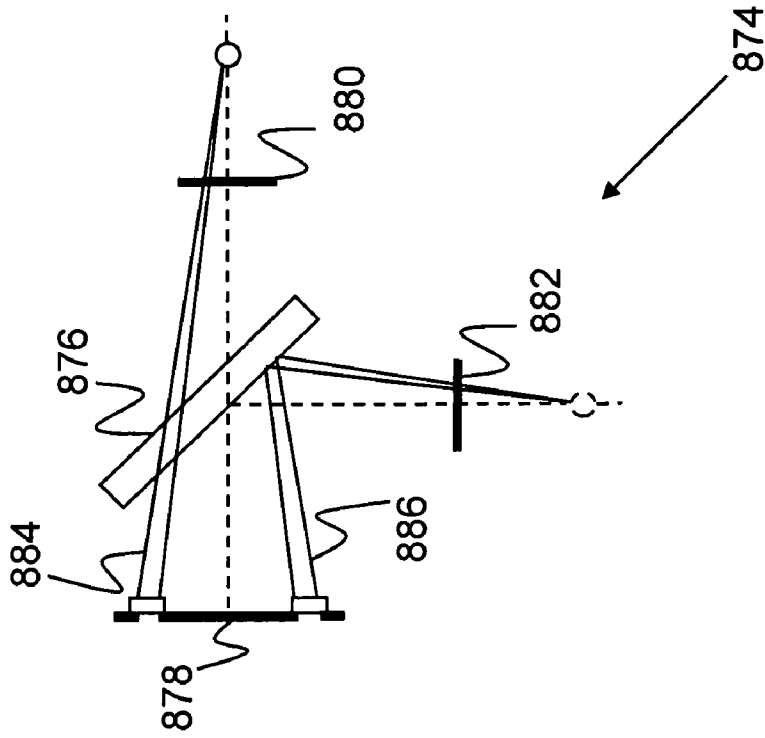

FIG. 8E

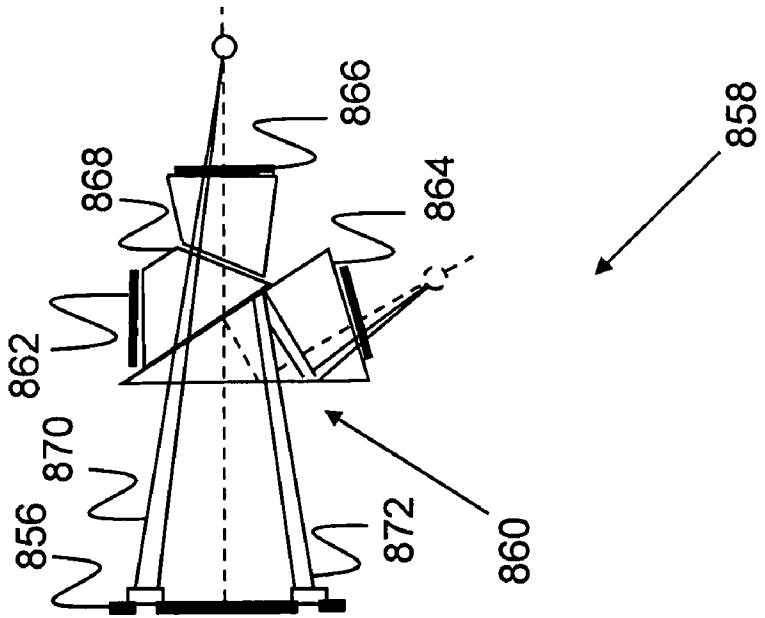

FIG. 8D

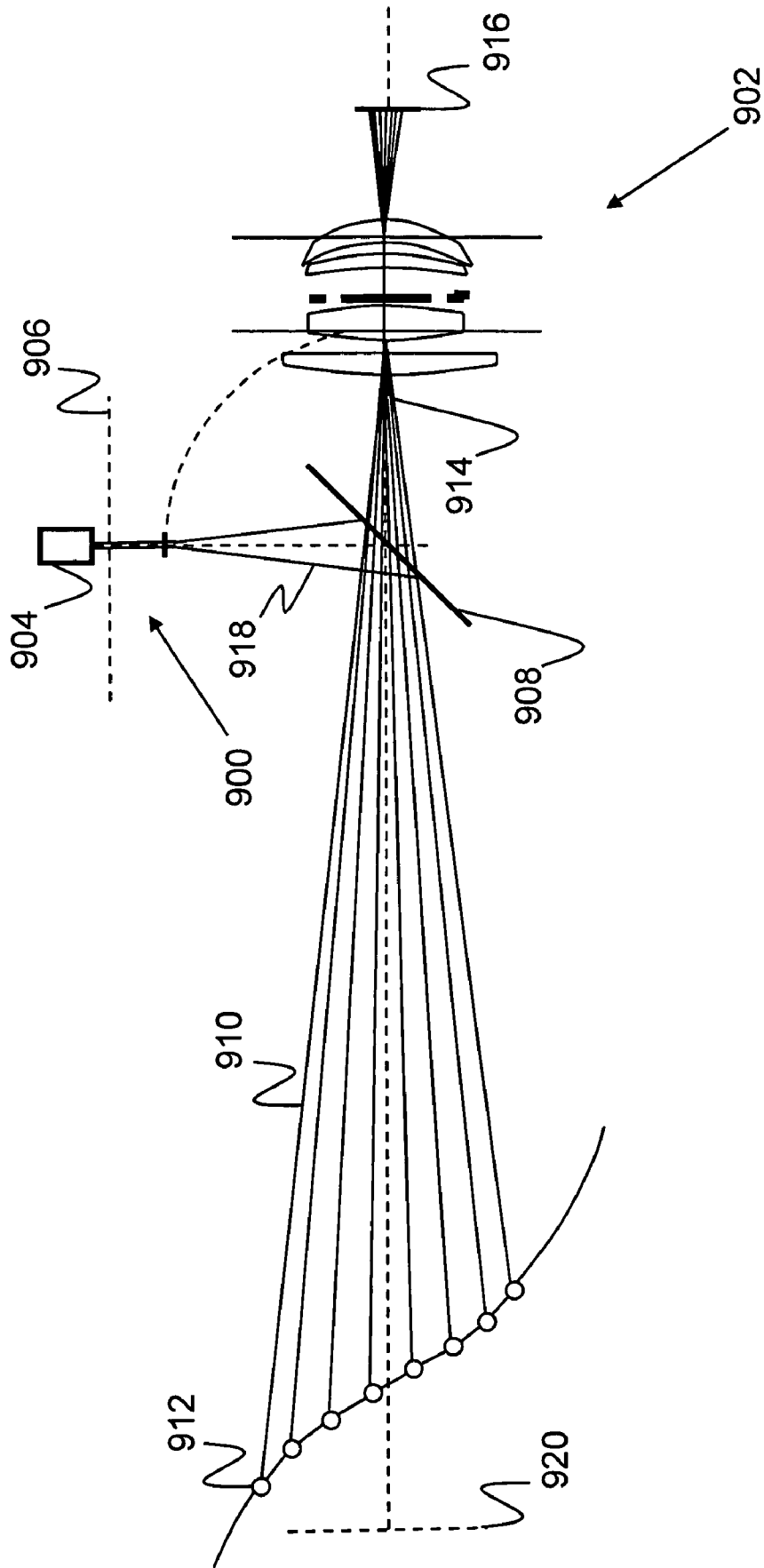

FIG. 9

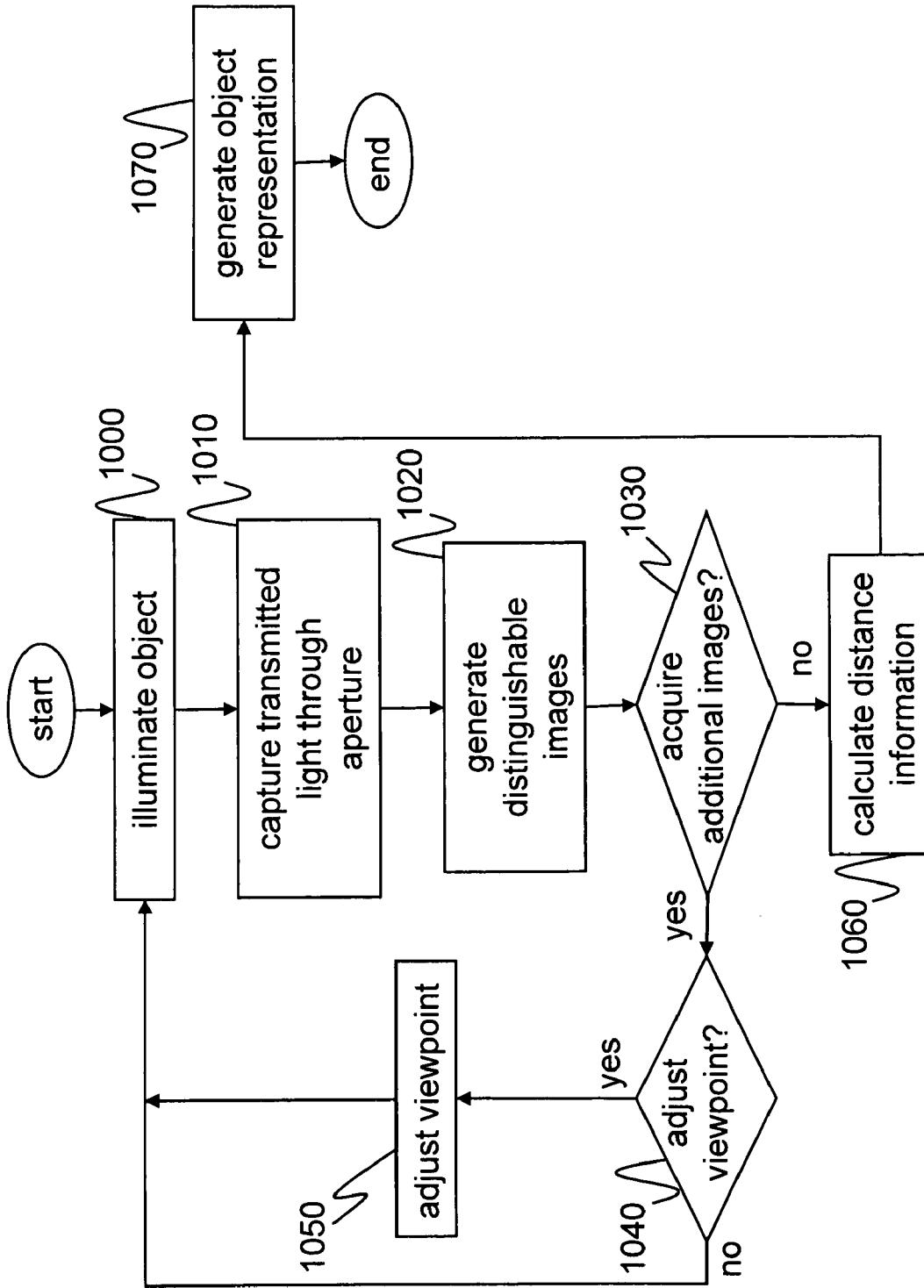

FIG. 10

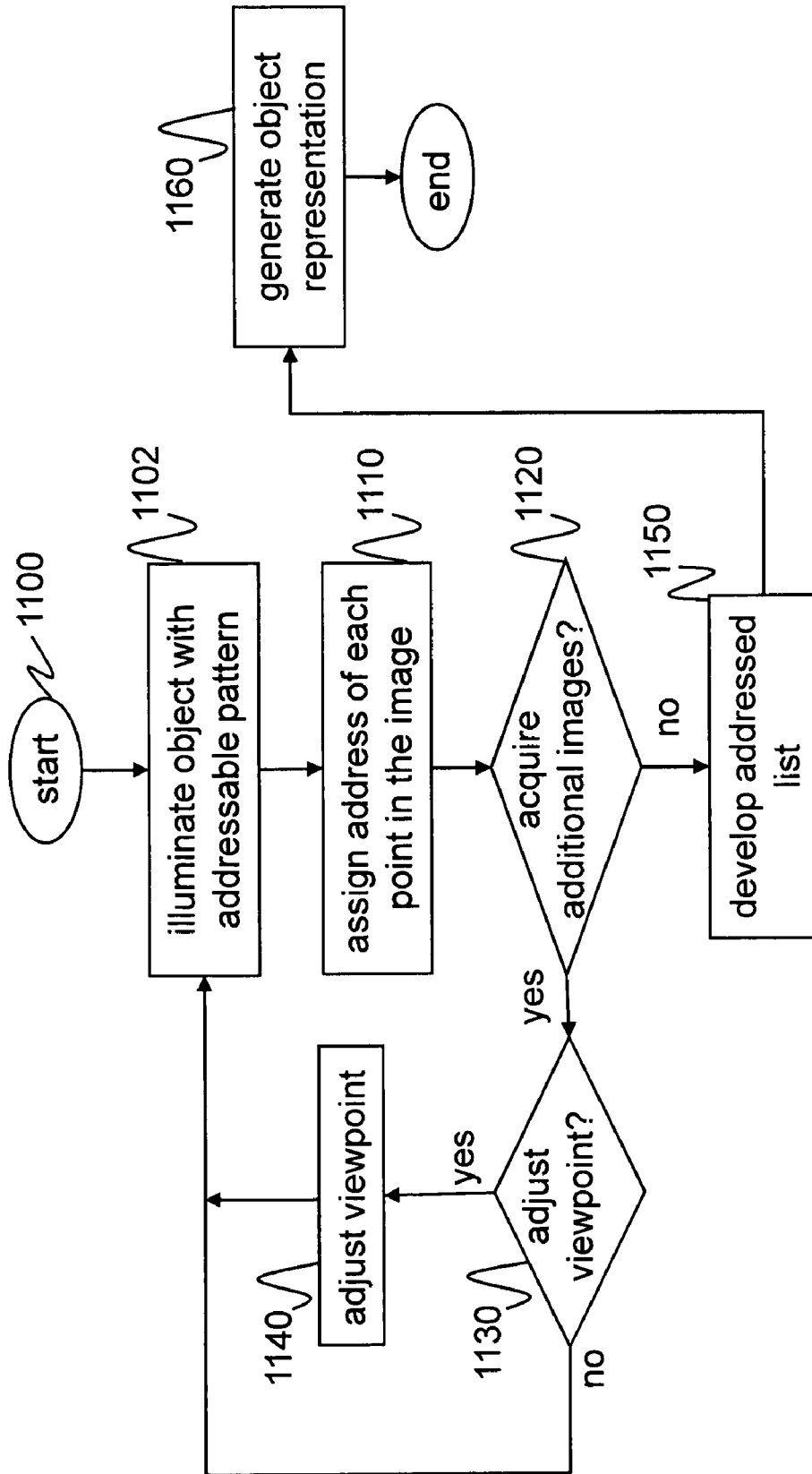

FIG. 11

**SINGLE-LENS, SINGLE-APERTURE,  
SINGLE-SENSOR 3-D IMAGING DEVICE**

PRIORITY CLAIM

The present application is a non-provisional patent application, claiming the benefit of priority of U.S. Provisional Application No. 60/925,918, filed Apr. 23, 2007, titled, "Single-lens, Single-aperture, Single-sensor 3-D Imaging Device;" U.S. Provisional Application No. 60/926,010, filed Apr. 23, 2007, titled "Single Lens Three-Dimensional imaging using Polarization-Coded Aperture Mask Combined with a Polarization-Sensitive Sensor;" and U.S. Provisional Application No. 60/926,023, filed Apr. 23, 2007, titled "An Aperture System with Spatially Biased Pinhole Shapes and Position (SDPSP) for Static and Dynamic 3-D Defocusing-Based Imaging with Single Sensor."

BACKGROUND OF THE INVENTION

(1) Technical Field

The present invention is related to a device and method for three-dimensional (3-D) imaging and, more specifically, to a single-lens, single-aperture, single-sensor 3-D imaging device that uses a defocusing technique.

(2) Background

Three-dimensional (3-D) imaging is a continuously evolving field that would benefit from improved imaging techniques. Enhanced 3-D imaging could be used for a variety of purposes, such as to generate quantitative information about an imaged object (through quantitative 3-D imaging). However, existing imaging techniques have failed to sufficiently support quantitative 3-D imaging. For example, when a point that is not on the focal plane of an imaging system is imaged through the imaging system, the captured point detected by a sensor is said to be defocused. If the imaging system has a large aperture, then the defocused point will appear blurred. For this reason, it has been suggested that the blur of the image of a point can be used to quantitatively determine the distance from that point to the focal plane in space. It has also been suggested that if the position of the focal plane is known, the imaging system could be used for quantitative 3-D imaging. To reconstruct the 3-D position of a point, it is only necessary to measure the size and/or intensity of the blur disc ( $Z$ ) and the point position on the sensor ( $X$ ,  $Y$ ).

In practice, however, such a system is difficult to effectively implement. First, a blurred image occupies a large amount of space on the sensor, so sophisticated algorithms to separate overlapped images are necessary. Second, the amount of light entering the optical system does not change appreciably between a focused point and a defocused point (unless the focal plane is very close to the optical system). Thus, the blurred image puts the same amount of energy onto the sensor as a focused image, but spread over a larger area. The intensity of a defocused image is inversely proportional to its area, so a quantitative measurement of the distance between the focal plane and a point based only on blur requires a sensor with an extremely high dynamic range. In real lenses, there are also diffraction effects which make blurred images look more like rings than broad Gaussian distributions in certain depth ranges, making software processing complicated. See, for example, Wu, M.; Roberts, J. W.; and Buckley, M., "Three-dimensional fluorescent particle tracking at micron-scale using a single camera," *Experiments in Fluids*, 2005, 38, 461-465. Even without lens aberrations or diffraction, image processing is complicated by the fact that

since the depth information comes from a measure of the diameter of a blur spot, the intensity of the imaged point affects the measurement. For example, if two defocused points A and B have the same amount of defocus, but point A is brighter than point B, typically point B's image will be measured as having a smaller diameter than point A's simply because it does not rise as far from the background illumination in the scene.

The original "defocusing" concept recognized that in such a blur-based system, the depth information is carried only by the marginal (outer) rays of the ray pencil that forms the image. See, for example, Willert, C. E.; and Gharib, M., "Three-dimensional particle imaging with a single camera," *Experiments in Fluids*, 1992, 12, 353-358. It is the angle that these rays make with the sensor plane that dictates the sensitivity of the imaging system. Thus, an equivalent measurement should be possible by placing small apertures off-axis in the imaging system, such that only marginal rays may pass through to form an image. If a blur system, as described above, has its large aperture replaced with a small aperture placed anywhere on the circumference of the large aperture, then the image of a defocused point is now a small spot located on what would otherwise be the circumference of a blurred image. The end result is depth information that is transmitted not by the size of a blurred spot, but rather by a lateral offset in a much smaller spot. Measuring the location of a spot on an image is much less sensitive to intensity differences than measuring its size.

The use of small apertures alleviates the dynamic range issues with a blur-based system, since the high f-number of the small aperture makes diffraction blur (not defocus blur) the primary blurring agent in the image. This means that within a large range of distances from the focal plane, the images are almost the same size.

Using off-axis apertures means that reconstruction of a point's position in space now involves finding all the images of a single point on the sensor and measuring the distance between them. The images will appear in the same pattern as the aperture arrangement; for example, if three small apertures arranged as vertices of an equilateral triangle are used, then the image of a defocused point is three small spots arranged in an equilateral triangle. The orientation of the images' triangle relative to the apertures' triangle reveals whether the defocused point is ahead of or in front of the focal plane. Additionally, the size of the images' triangle relates to the distance between the defocused point and the focal plane. The size of the triangle is zero for a focused point which occurs when all three images are on top of each other. The size of the triangle increases as the amount of defocus increases. Multiple small images take up less space on the sensor than one large blurred one, so the overlap problem is alleviated by this arrangement.

The matching problem in the reconstruction creates a new problem; if the object being imaged is a set of featureless points, then the images are indistinguishable and can only be matched according to their relative location (for example, finding all dots on an image that form equilateral triangles within some tolerance). This relatively loose matching criterion necessitates that three or more apertures be used to reduce the number of mismatches or "ghosts."

A single off-axis aperture records depth information; however,  $Z$  cannot be separated from the in-plane position of the point imaged. Two apertures record the depth information and allow the in-plane position to be extracted independently of  $Z$ . In practice, it is impossible to reconstruct a random point cloud with only two apertures because many ghost particles are generated when images are mismatched. Moreover, it is

impossible to know if a particle was in front of or behind the focal plane from only two images. With three apertures, mismatches are reduced and the sign of the distance from the particle to the focal plane is known by the orientation of the triangle formed by the images. See, for example, Willert, C. E.; and Gharib, M., "Three-dimensional particle imaging with a single camera," *Experiments in Fluids*, 1992, 12, 353-358.

The original practical implementation of the defocusing concept consists of a single lens with three off-axis apertures imaging onto a single monochromatic sensor (i.e., three were deemed the minimum number of apertures that produced acceptable results). It should be noted that because the defocusing measurement is a measurement of a point's position relative to the focal plane, it is necessary to know the position of the device to know the absolute position of desired point.

The three off-axis apertures imaging onto a single monochromatic sensor also has disadvantages. Overcrowding of the sensor is still an issue when the point density within the scene is high. In this case, each point has up to three images on the sensor and there is still a possible dynamic range issue (i.e., a point on the focal plane will have three images that coincide on the sensor and thus will look three times as bright as defocused points). The dynamic range issue can be overcome by selectively illuminating the volume so that no points on the focal plane are imaged.

As described in U.S. Pat. Nos. 6,955,656 and 7,006,132, one solution to the overcrowding problem is to image each aperture with a separate sensor. This adds to the matching criterion, because now each spot on the image can only be one of the vertices of the aperture arrangement; since the source (aperture) of each spot is known, there is slightly less ambiguity in the matching process.

Further, the addition of more sensors (for example, a charge-coupled device (CCD)) has the disadvantages of higher cost and larger size (along with manufacturing complications) relative to a single-sensor system. Moreover, multiple-sensor arrangements pose alignment challenges and robustness challenges; the multiple sensors are also differently affected by temperature, vibration, and other environmental effects and as such are more prone to calibration errors.

For the foregoing reasons, there is a need for a quantitative 3-D imaging system which either alleviates or eliminates the matching problem. The system should be viable in a single-lens, single-sensor arrangement for simplicity and compactness and also should be easily expandable to a multiple-lens, multiple-sensor arrangement if so desired.

### SUMMARY OF THE INVENTION

The present invention is related to a device and method for 3-D imaging, and more specifically to a single-lens, single-aperture, single-sensor 3-D imaging device that uses a defocusing technique.

The device comprises a lens, a substantially oblong aperture obstructing the lens, a sensor operable for capturing electromagnetic radiation transmitted from an object through the lens and the substantially oblong aperture, and a processor communicatively connected with the sensor for processing the sensor information and producing a 3-D image of the object.

In another embodiment, the substantially oblong aperture comprises an asymmetric shape.

In yet another embodiment the oblong aperture is rotatable, whereby an orientation of an observed pattern relative to the

oblong aperture is varied with time thereby minimizing ambiguity generated by image overlap.

In another embodiment, the device further comprises a projection system configured to project a predetermined pattern of electromagnetic radiation onto a surface of the object thereby allowing for mapping of unmarked surfaces in three dimensions.

In a further embodiment, the sensor comprises rows and columns of pixels, the substantially oblong aperture has a major axis and a minor axis, and the axes are aligned with the rows and columns of the sensor.

In another embodiment of the present invention, the device further comprises a projector which projects a line onto a surface of the object, such that the line is at a substantially right angle to the substantially oblong aperture.

As can be appreciated by one skilled in the art, the present invention also comprises a method for three-dimensional (3-D) imaging of an object, the method comprising acts of capturing electromagnetic radiation transmitted off of an object and through a lens and a substantially oblong aperture with a sensor, and processing information from the sensor to produce a 3-D image representative of the object.

In another embodiment of the method, the substantially oblong aperture comprises an asymmetric shape.

In another embodiment, the method further comprises an act of rotating the substantially oblong aperture, whereby an orientation of an observed pattern relative to the oblong aperture is varied with time thereby minimizing ambiguity generated by image overlap.

In yet another embodiment, the method further comprises an act of projecting a predetermined pattern of electromagnetic radiation onto a surface of the object thereby allowing for mapping of unmarked surfaces in three dimensions.

In a further embodiment of the method of the present invention, sensor comprises rows and columns of pixels, the substantially oblong aperture has a major axis and a minor axis, and the axes are aligned with the rows and columns of the sensor.

In another embodiment, the method further comprises an act of projecting a line onto a surface of the object, such that the line is at a substantially right angle to the substantially oblong aperture.

### BRIEF DESCRIPTION OF THE DRAWINGS

The objects, features and advantages of the present invention will be apparent from the following detailed descriptions of the disclosed aspects of the invention in conjunction with reference to the following drawings, where:

FIG. 1A is an illustration showing a band-pass filter system that includes a sensor;

FIG. 1B is an illustration showing a defocused, multiple, pattern-coded image acquisition of real points as received by the sensor of FIG. 1A;

FIG. 1C is an enhanced-view illustration showing the framed area of FIG. 1B, demonstrating the matching procedure for a multi-wavelength addressable-pattern in the form of a red dot and its corresponding green dot;

FIG. 1D is a illustration showing a chart of the relationship of focal length (L) to Z-distance of matches and "ghost" particles with respect to FIG. 1C;

FIG. 2 is an illustration showing a polarized filter imaging system;

FIG. 3 is an illustration showing an aperture system for imaging points;

5

FIG. 4A is an illustration showing a synched, single-aperture system with a single-hole mask shown in a first position A;

FIG. 4B is an illustration showing a synched single-aperture system with a single-hole mask shown in a second position B;

FIG. 4C is an illustration showing a rotatable aperture along with the images of two objects produced at different angles of rotation;

FIG. 5A is an illustration showing a single-aperture system having multiple f-stops;

FIG. 5B is an illustration showing an image acquired from the sensor of a single-aperture, multiple f-stop system;

FIG. 5C is an enhanced-view illustration showing the framed area of FIG. 5B;

FIG. 5D is an illustration showing a chart of matched points as determined by a processor;

FIG. 5E is an illustration showing a vibrating, single-aperture system;

FIG. 5F is an illustration showing an asymmetrical aperture, and a comparison view of the corresponding images produced by an object in front of versus in back of the focal plane;

FIG. 5G is an illustration showing a large central aperture;

FIG. 5H is an illustration showing a central aperture with off axis defocusing apertures;

FIG. 6A is an illustration showing an electronically masked imaging system with a first, multi-window electronic aperture open;

FIG. 6B is an illustration showing an electronically masked imaging system with a second, multi-window electronic aperture open;

FIG. 7A is an illustration showing an addressable template pattern suitable for projection onto a surface of an object of interest;

FIG. 7B is an illustration showing an acquired image taken of a target object using an addressable template;

FIG. 7C is an illustration showing an acquired image and partial grid;

FIG. 7D is an illustration showing a reconstructed illustration of the center sample of FIG. 7C;

FIG. 8A is an illustration showing a non-laser pattern projector and imaging system;

FIG. 8B is an illustration showing a two prism off-set and two-sensor system;

FIG. 8C is an illustration showing a one silvered offset prism and two-sensor system;

FIG. 8D is an illustration showing a three CCD-sensor assembly system;

FIG. 8E is an illustration showing a narrow-band mirror sensor assembly system;

FIG. 9 is an illustration showing a laser pattern projector and imaging system;

FIG. 10 is a flow chart showing the acts of acquiring and processing images in order to develop a representation of the surface of an object; and

FIG. 11 is a flow chart showing the incorporation of an addressable-pattern to an imaging system in order to aid in image reconstruction.

#### DETAILED DESCRIPTION

The present invention satisfies the long felt need for an inexpensive and precise way of three-dimensional imaging (e.g., mapping). Aspects of the invention are applicable to surface and volume inspection of manufactured parts, comparing actual products versus the original design, scanning of

6

3-D objects, evaluation of body parts (hernias, arteries, pre- and post-plastic surgery, etc.), surface roughness evaluation, and real-time feedback of surface deformation. In the following detailed description, numerous specific details are set forth in order to provide a more thorough understanding of the present invention. However, it will be apparent to one skilled in the art that the present invention may be practiced without necessarily being limited to these specific details. In other instances, well-known structures and devices are shown in block diagram form, rather than in detail, in order to avoid obscuring the present invention.

The reader's attention is directed to all papers and documents which are filed concurrently with this specification and which are open to public inspection with this specification and, the contents of all such papers and documents are incorporated herein by reference. All of the features disclosed in this specification, (including any accompanying claims, abstract, and drawings) may be replaced by alternative features serving the same, equivalent or similar purpose, unless expressly stated otherwise. Thus, unless expressly stated otherwise, each feature disclosed represents a non-limiting example of a generic series of equivalent or similar features.

Furthermore, any element in a claim that does not explicitly state "means for" performing a specified function, or "step for" performing a specific function, is not to be interpreted as a "means" or "step" clause as specified in 35 U.S.C. Section 112, Paragraph 6. In particular, the use of "step of" or "act of" in the claims herein is not intended to invoke the provisions of 35 U.S.C. 112, Paragraph 6.

First, an introduction to the present invention is provided to give an understanding of the general aspects. Next, defocusing methods based on light properties and mask shape are discussed with respect to feature mapping. Then, aspects of single aperture systems are discussed with respect to feature mapping. Subsequently, examples of pattern matching are provided. Next, imaging methods according to the present invention are provided. Next, a discussion of image matching is provided.

#### (1.0) Introduction

Blur from defocus can be used to measure the distance between a point and the focal plane of a lens. The present invention proposes added dimensions in terms of optical and illumination techniques to the single-lens multiple-aperture arrangement that overcome the shortcomings of the original defocusing concept. The following aspects allow for robust measurement of an object surface with a single-lens, single-sensor, and multiple-aperture device.

Optical modifications to the multiple-aperture arrangement physically mask and convey filtered information to the sensor in such a way that each aperture produces a separable image for reconstructing an object surface. In order to produce a separable image, the aperture mask may be modified by altering the shape of the aperture, by coding the transmittance of the aperture, or by providing a single-slit mask whose hole moves about the aperture plane during or between exposures. Each of the aperture masks provides additional information which aids in representing the desired features of an object.

A single-lens, single-sensor, multiple aperture device may be further augmented to obtain additional information from the object by using registered information. Registered information may be obtained from the distinguishing characteristics of the object, from information projected onto the surface of the object, or from information or markers placed directly onto the object.

For large objects which cannot be captured with a single exposure, the aforementioned aspects may provide informa-



tion which may be used to fit multiple exposures together in order to recreate surface features of a desired object. Alternatively, multiple images can be scanned in for both large and small objects in order to produce a high resolution representation of the object or object feature. The matching concept is equally applicable to stereo vision systems.

Aspects of the present invention will now be described more fully hereinafter with reference to the accompanying drawings, in which preferred embodiments of the invention are shown. This invention may be embodied in many different forms and should not be construed as limited to the embodiments set forth herein. Further, the dimensions of layers and other elements shown in the accompanying drawings may be exaggerated to more clearly show the details. The present invention should not be construed as being limited to the dimensional relations shown in the drawings, nor should the individual elements shown in the drawings be construed to be limited to the dimensions shown.

#### (2.0) Light Property and Shape-Based Systems

A masked aperture generates a distinguishable image as light or other electromagnetic radiation from an illuminated object is passed through a lens, through a masked aperture, and onto a sensor suitable for receiving the information from the masked aperture. The masked aperture passes coded and defocused information of the object onto a suitable sensor. The defocused information provides a measurement of a point on an object relative to the focal plane. The coded information from the masked aperture provides the information required in order to separate overlapping images and match corresponding points detected by the sensor. Please note that although the term "light" may be used when describing various embodiments of the present invention, the present invention is suitable for use over any portion of the electromagnetic spectrum, including but not limited to microwaves, infrared radiation, ultraviolet radiation, and X-rays. The use of the term "light" is for exemplary purposes and is not intended to limit the scope of the present invention to the visible portion of the electromagnetic spectrum.

When two or more masked apertures are used, each mask is ideally different from the other such that the intensity versus wavelength properties and/or morphology of detected shapes from the masked aperture(s) are easily distinguishable on the sensor. A variety of filtering apertures may be used in order to selectively filter light according to its properties onto a light sensor such that the images from each aperture are distinguishable. Further, when the shapes of two or more apertures are distinguishable, each aperture image detected by the sensor is also distinguishable. Therefore, non-limiting examples of suitable aperture masks and filters include wavelength band-pass filters, light polarization filters, and differentially-shaped masks.

#### (2.1) Color Coded Filters

Referring to FIG. 1A, a band-pass filter system 100 is shown. The band-pass filter system 100 includes a lens 102, a mask 104 having a red aperture 106 and a green aperture 108, and a sensor 110. Although shown as a red and a green aperture 106 and 108, respectively, any number and combination of color filtered aperture may be used in combination with an appropriate sensor 110. Thus, while the apertures are referred to specifically as the red and green apertures 106 and 108, respectively, the apertures are not intended to be limited to these colors and could, alternatively, be referred to as a first aperture, a second aperture, and so forth.

The band-pass filter system 100 produces a representation of an illuminated object 112 when the object 112 is placed in front of a focal plane 114. Scattered light 116 is reflected from the surface of the illuminated object 112 and through the lens

102. Once through the lens 102, the scattered light 116 selectively passes through either the red aperture 106 or the green aperture 108, or is reflected off of or absorbed by the mask 104. Transmitted red light 118 from the red aperture 106 and transmitted green light 120 from the green aperture 108 are then recorded on the sensor 110 positioned in front of a focal image point 122. As can be appreciated by one skilled in the art, the color of light used to illuminate the object can also be selected such that it only passes through a desired aperture or set of apertures. Use of narrow-band light projectors can be useful in situations where one set of apertures is used to capture defocusing information in one color, while another aperture is used to project a realistic visual image of the object in another color, so that the two are readily distinguishable.

Referring to FIG. 1B, a defocused, multiple color-coded image acquisition 124 of real points is shown as received by the sensor 110 of FIG. 1A. Each color-coded acquisition 124 corresponds with a multi-wavelength addressable-pattern created by the respective aperture 106 and 108. As shown in FIG. 1B, each real point on the object is represented with multi-wavelength-addressable-pattern red dots 126 and green dots 128. As can be appreciated by one skilled in the art, the red and green dots 126 and 128 are a result of the red and green apertures, respectively; however, the invention is not limited thereto as the color of the dots would vary according to the color of the apertures. Corresponding red dots 126 and green dots 128 are shown linked together with a correspondence line 130. The correspondence lines 130 are not visible; however, they are useful tools for highlighting the difficulty of matching points in color-coded image acquisitions 124. Only the dots connected by correspondence lines 130 actually correspond together. Without the mask 104, there would not be enough information to link corresponding points.

Referring to FIG. 1C, an enhanced view of the framed area 132 of FIG. 1B illustrates the procedure for matching a corresponding red dot 126 and green dot 128. When the multiple color-coded image acquisition 124 has been developed, a processor then begins a search for all of the color coded dots within the image. Alternatively, the search may be conducted from raw data (i.e., an actual image 124 need not be produced). Instead, the sensor 110 is coupled with a processor which receives the sensor information directly. In either case, once all dots have been detected, the matching process begins with an assumption of the relative position of the illuminated point 112 with respect to the focal plane 114. The relative position of the illuminated point 112 with respect to the focal plane 114 may be known a priori, entered by a user, determined by software, or determined by sensors. For illustrative purposes, here it is postulated that the illuminated point 112 of the object is in front of the focal plane 114. Therefore, the matching begins with the instruction command, for example: "Any green dot 128, 136, 138, and 140 to the right of a red dot 126, 142, 144, and 146 on a line corresponding to a line connecting the two apertures (within a tolerance) is a match." The first red dot 126 is detected, and then matched to the first green dot 128 within tolerance 134 of the red dot 126 according to the instruction command. The tolerance 134 in this case is denoted as a distance from the red dot 126 in the form of a radius. However, the tolerance 134 may take the form of any desired shape or distance. Supplemental searches conducted for green dots 136, 138, and 140 within the tolerance 134 of the red dot 126 produces a total of three "ghost" matches (green dots 136, 138, and 140, respectively).

Referring to FIG. 1D, the relationship of focal length (L) to Z-distance of matches and "ghost" particles with respect to FIG. 1C is shown. The matching of the red dot 126 to all of the green dots 128, 142, 144, and 146 results in one match 148

and three ghosts **150**, **152**, and **154**. The match between the red dot **126** and the green dot **128** is used to calculate the Z-to-L relationship of the first matched point **148**. The mismatch between the red dot **126** and the green dots **136**, **138**, and **140** provides the first three ghosts **150**, **152**, and **154**, respectively.

With respect to the second red dot **142**, one match **156** and two ghosts **158** and **160** are produced. The match between the second red dot **142** and the corresponding green dot **136** is used to calculate the Z-to-L relationship of the second matched point **156**. The mismatch between the red dot **142** and green dots **138** and **140** is represented by the two ghosts **158** and **160** respectively.

With respect to the third red dot **144**, one match **162** and two ghosts **158** and **160** are produced. The ghosts **158** and **160** are dots that are not assignable to a corresponding dot from the other aperture. The match between the third red dot **144** and the corresponding green dot **138** is used to calculate the Z-to-L relationship of the third matched point **162**. The single mismatch between the red dot **144** and green dot **140** is represented by the ghost **164**.

Finally, with respect to the fourth red dot **146**, one match **162** but no ghosts are generated. The match between the fourth red dot **146** and the corresponding green dot **140** is used to calculate the Z-to-L relationship of the fourth and final matched point **166**. Since there are no other green dots to the right of the red dot **146** other than the matching green dot **140**, no additional mismatches exist for the framed area **132** of FIG. 1C.

Determining the Z-to-L relationship between matches and “ghost” particles is greatly enhanced by differentially-coded points, such as those shown **126** and **128** in FIG. 1B. In a non-separable case, one in which there is no color information provided by an aperture mask **104**, there are many more ghosts because, without having a differentiator like color, each “red dot” of FIG. 1A can be matched with any other “red dot” producing many more ghosts. Further, no assumptions can be made that any given dot by itself is not, in fact, two dots on top of the other, adding even more ghosts at the focal plane.

#### (2.2) Polarized Filters

Please note that although the term “light” may be used when describing various embodiments of the present invention, the present invention is suitable for use over any portion of the electromagnetic spectrum, including but not limited to microwaves, infrared radiation, ultraviolet radiation, and X-rays. The use of the term “light” is for exemplary purposes and is not intended to limit the scope of the present invention to the visible portion of the electromagnetic spectrum.

Coded information may be provided to a sensor in any number of ways. As a non-limiting example, FIG. 2A illustrates a polarized filter imaging system **200**. The polarized filter imaging system **200** includes a lens **202**, a mask **204** having a horizontal polarizing aperture **206** and a vertical polarizing aperture **208**, and a sensor **210** capable of distinguishing between polarizations. Although shown as a combination of horizontally and vertically polarized apertures **206** and **208** respectively, any number and combination of at least nearly orthogonal pairs of orientations may be used.

The polarized filter imaging system **200** produces a representation of the illuminated object **212** when placed in front of the focal plane **214**. Scattered light **216** is reflected from the surface of the illuminated object **212** and through the lens **202**. Once through the lens **202**, the scattered light **216** selectively passes through either the horizontal polarizing aperture **206** or the vertical polarizing aperture **208**, or is reflected off of the mask **204**. The transmitted horizontally polarized light **218** from the horizontal polarizing aperture **206** and the trans-

mitted vertically polarized light **220** from the vertical polarizing aperture **208** is then recorded on the sensor **210** positioned in front of the focal image point **222**.

By differentially coding the horizontal polarizing aperture **206** and a vertical polarizing aperture **208**, distinguishable dots, similar to those shown in FIG. 1B, are obtained. However, the coded information obtained from the present polarized aspect provides polarization markers instead of color-coded dots.

A similar result can be obtained by using at least one polarization-coded aperture as shown in FIG. 2B, where if the at least one aperture is rotated from a first aperture position **224** to a second aperture position **226** with an exposure taken at each position, the polarization of the aperture will change between exposures, resulting in mutually distinct sets of polarized images **228** and **230** from the first exposure **228** and the second exposure **230** respectively, whereby the depth information can be determined by measuring the distance between images **228**, **230** from the same marker **232** on different exposures.

Selectively transmitting light (as is the case with a band-pass filter system **100**) or exploiting properties of light (as is the case with a polarized filter imaging system **200**) are effective means of coding information received by a sensor. Ultimately, the coded information detected by the sensor eases the matching task described with respect to FIG. 1C and FIG. 1D.

#### (2.3) Spatially-Biased Apertures

Referring to FIG. 3A, a differentially-shaped aperture system **300** for imaging points small enough to be considered nearly point sources, is shown. The differentially-shaped aperture system **300** includes a lens **302**, a mask **304** having a circular-shaped aperture **306** and a square-shaped aperture **308**, and a sensor **310**. Although shown as a circular-shaped aperture **306** and a square-shaped aperture **308**, any number and combination of different shape-filtered apertures may be used. Non-limiting examples of suitable shapes include convex polyhedrons, concave polyhedrons, circular shapes, polyforms, and combinations thereof.

The differentially-shaped aperture system **300** produces two representations **314** and **316** of the illuminated object **312** per exposure. Each shape **314** and **316** detected by the sensor **310** corresponds to the shape of the respective aperture **306** and **308**, respectively. As scattered light **320** is reflected off the surface of the illuminated object **312** and through the lens **302**, it will either pass through the circular-shaped aperture **306**, the square-shaped aperture **308**, or be reflected by the mask **304** and beyond the sensor focal plane **318**. The transmitted light **322** which passes through the circular-shaped aperture **306** produces a circular pattern **314** on the sensor **310**. Similarly, the transmitted light **324** which passes through the square-shaped aperture **308** produces a square pattern **316** on the sensor **310**. After multiple acquisitions, the numerous circular patterns **314** and square patterns **316** are detected and then matched by a processor **326** based upon a matching rule. Both the matches and ghosts may then be plotted on a Z-to-L plot, such as the one depicted in FIG. 1D. Alternatively, a plot demonstrating the matches without ghost images may also be generated.

In addition to apertures of different shape, spatially-biased apertures can also comprise similarly shaped apertures **326** and **328** located at different radial positions from the center of the mask **329**, as shown in FIG. 3B. When this arrangement of apertures is rotated from a first position **326** and **328** to a second position **330** and **332** and an exposure is taken at each position (sequential time-delayed imaging), the distance of the aperture from the center of the mask **329** will determine

the rate with which images **336** and **338** produced by an object change their position on the imager **334**, where the rate of change physically manifests as the distance the image moves between exposures.

Another embodiment of spacially-biased apertures suitable for use with the present invention are apertures of similar shape but different size, for example, two circular apertures, where one is larger than the other. Using apertures of different size effectively performs the same function as using apertures of different shape, as described above and shown in FIG. 3A. (3.0) Single Aperture System

Referring to FIG. 4A and FIG. 4B, a synced single-aperture system **400** including a lens **402**, a single-hole mask **404**, a moving aperture **406**, a sensor **408**, and a processor **410** in communication with the sensor **408**, is shown. Additionally, the single-hole mask **404** is shown in a first position A and a second position B, respectively. An illuminated object **412** may be reconstructed by selectively allowing reflected rays **414** to pass through the lens **402** and the aperture **406** of the single-hole mask **404**. The position of the single-hole mask **404**, whose moving aperture **406** moves about the aperture plane between exposures, is recorded by the processor **410**. As shown in FIG. 4A, the moving aperture **406** transmits light **416** and produces a first point **414** detected by the sensor **408**. The first position information of the moving aperture **406** during the first exposure is recorded by the processor **410** as shown in FIG. 4A. For the second exposure, the moving aperture **406** is moved to the second position B (shown in FIG. 4B). As shown in FIG. 4B, the moving aperture **406** transmits light **418** and produces a second point **420** detected by the sensor **408**. The second position information of the moving aperture **406** during the second exposure is recorded by the processor **410**. The first point **414** and first position information and second point **420** and second position information are then used to match the first point **414** from the first exposure with those of the second point **420**. Alternatively, the color of the reflected rays **414** may be altered between the first exposure and second exposure in order to provide additional information which may be used to aid in the matching process.

Similarly the problem of mismatching can be alleviated by rotating the aperture **422** as shown in FIG. 4C. When a plurality of image acquisitions have been taken relative to the oblong aperture by rotating the aperture over time, overlapping images can be distinguished, thereby alleviating the ambiguity generated by image overlap. The figure shows a comparison of the images formed by two objects **424** positioned in a horizontal plane with the aperture at a first aperture position **422**. In the first aperture position **432** the objects' images **426** overlap, causing a potential mismatch. When the aperture is rotated to a second aperture position **428**, however, the images formed are distinguishable **430**.

### (3.1) Single Slit-Aperture System

Referring to FIG. 5A, a single-aperture system **500** having multiple f-stops is illustrated. The differentially-shaped aperture system **500** includes a lens **502**, a mask **504** having a substantially oblong aperture **506**, a sensor **508**, and a processor **510** in communication with the sensor **508**. Although shown as a roughly oblong-shaped aperture **506**, in general, any aperture which is significantly longer in length than in width may be used regardless of shape.

An illuminated object **512** may be reconstructed by selectively allowing reflected rays **514** to pass through the lens and the substantially oblong aperture **506** of the mask **504**. Notably, the single-aperture system **500** uses a long, narrow, slit-aperture **506**, instead of a standard circular aperture. Effectively the slit aperture **506** has a different f-number in two

directions. The long length of the slit aperture **506** produces a low f-number which generates a large variance disc **516** on the sensor **508**. Conversely, the narrow width of the slit aperture **502** produces a high f-number, generating a minimum variance, such that the image of a point source is represented by lines **518** rather than discs **516**. The intensity can now be thought of as varying inversely with length rather than area, so the dynamic range required on the sensor is much decreased relative to a pure-blur system. Further, the size of the produced images **516** and **518** only increase in one direction, minimizing the chance for overlap.

Also, the slit aperture could be made to be asymmetric in shape **542** as shown in FIG. 5F. The purpose of the asymmetry is to allow the sensor **544** to determine whether an object is located in front of **546** or in back of **548** the focal plane **550**. An object located in back of **548** the focal plane **550** will produce an inverted image **552** on the sensor **544**, while an object located in front of **546** the focal plane **550** will produce a normal image **554**. However, if the aperture is symmetrically shaped **506** as in FIG. 5A, the image produced **516** by an object in back of **548** the focal plane **550** will be indistinguishable from one located at the corresponding location in front of **546** the focal plane **550**. By using an asymmetrical aperture **542**, these objects in front of **546** and in back of **548** the focal plane **550** can be distinguished. The asymmetric aperture **542** shown in FIG. 5F has a circular hole at one end of the overall oblong shape, but any asymmetrically shaped aperture will produce the same effect.

Referring to FIG. 5B, an image **520** acquired from the sensor **508** of a single-aperture multiple f-stop system **500** is shown. Within the frame **522** of the image **520**, multiple plots **524**, **526**, **528**, and **530** with different Z-coordinates are shown. Although shown as an image **520**, the information depicted may also be conditioned and sent via a signal to a processor **510** for processing.

Referring to FIG. 5C, the framed area **522** of the acquired image of FIG. 5B is processed in order to find the multiple f-stop streaks **524**, **526**, **528**, and **530** corresponding with the aperture movement. Once all of the multiple f-stop streaks **524**, **526**, **528**, and **530** have been found, a rule is applied to determine the Z-to-L relationship. Notably, no matching is required.

By assuming all of the points were in front of the focal plane "L," the multiple f-stop streaks **524**, **526**, **528**, and **530** are used to calculate the Z-to-L relationship. An example of matched points **532**, **534**, **536**, and **538** determined by a processor **510** are shown in FIG. 5D. In general, the processor **510** connected with the sensor **508** may be used to collect the raw data obtained from the sensor. The processor **510** then may use the Z-to-L relationships in order to calculate the depth information of each detected f-stop streaks **524**, **526**, **528**, and **530**. The processor **510** may then be used to generate a representation of the object from the depth information of each illuminated point **512**. In another aspect, the processor **510** may also include memory. The memory may be used to store calibration information of previously sampled points at known distances. The calibration information may be stored as a look-up table in the image-acquisition system for fast in-line processing. Alternatively, the calibration information may be stored remotely and accessed by the processor.

The results depicted in FIG. 5B, FIG. 5C, and FIG. 5D may also be obtained by using a vibrating, single-aperture system **540** such as the one illustrated in FIG. 5E. The vibrating, single-aperture system **540** includes a lens **502**, a mask **504** having a single moving aperture **506**, and a sensor **508**.

An illuminated object **512** may be reconstructed by selectively allowing reflected rays **514** to pass through the lens and

the substantially oblong aperture **506** of the mask **504**. Notably, the single-aperture system **500** uses a moving aperture **506**, effectively simulating the effect of having a different f-number in two directions. As the moving aperture **506** controllably oscillates right to left in the direction of A and B (or in any other suitable direction), the net displacement of the moving aperture **506** from A to B produces a low f-number. The low f-number of this lateral movement from A to B generates a large variance disc **516** on the sensor **508**. Further, as the moving aperture **506** moves from A to B, there is no net change to the vertical diameter of the moving aperture **506**. The constant height of the moving aperture **506** therefore produces a high f-number, generating a minimum variance, such that the image of a point source is represented by lines **518** rather than discs **516**. The intensity is dependent upon the amount of time the aperture **506** spends at a particular axial position, thus image generated by this technique look more like bright ends connected by dimmer straight lines. Further, the size of the produced images **516** and **518** only increase in one direction, minimizing the chance for overlap.

In one aspect, the invention can be thought of as a two-aperture system with the ambiguity of matching removed by simply connecting the two aperture images physically on the imager. When imaging large objects through the aperture (not point sources), three images are visible. The center image is the image of the object, and the outer two images are formed as a result of diffraction and lens effects. As the scale of the object decreases, it approaches a point source, and at the limiting case, the image of the point source object has the same shape as the aperture.

### (3.2) Large Central Aperture with Off-Axis Defocusing Apertures

Please note that although the term “light” may be used when describing various embodiments of the present invention, the present invention is suitable for use over any portion of the electromagnetic spectrum, including but not limited to microwaves, infrared radiation, ultraviolet radiation, and X-rays. The use of the term “light” is for exemplary purposes and is not intended to limit the scope of the present invention to the visible portion of the electromagnetic spectrum.

The problem of mismatching can also be alleviated by using a large central aperture **556** in conjunction with at least one off-axis defocusing aperture **558** as shown in FIG. **5G**. The central aperture **556** can be a central variable aperture as in a typical camera. Effectively, the central aperture **556** has a different f-number than the defocusing apertures **558**. This means that at all times a substantially full image **560** of the object **561** is present on the sensor **562** via the central aperture **556** with superimposed defocused dots **564** from the defocusing apertures **558**.

Having the object image available at all times serves three purposes. First, it allows an operator to see where the device is pointed. Second, the object image provided by the central aperture can be matched with the physical x-y-z locations of points imaged by the defocusing apertures to produce a map of the object surface (see section 4.0 “Pattern Matching” below). Finally, it allows an accurate estimate of “POISE” (position and orientation) from two-dimensional (2-D) images produced by the device with respect to the object. Various methods for determining “POISE” are well known in the art. Existing “POISE” methods can use features of the background image or pre-positioned marked points to make their estimations. When using features of the background image, camera position can be obtained by proper rotation, de-warping, and scaling of the actual image obtained by the central aperture from different camera positions. In the case where a light projection system is used, the points of light

projected onto the object and imaged through the central aperture can be used to obtain camera position. Examples of suitable “POISE” methods for use with the present invention can be found in U.S. Application Publication No. 2007/0103460A1 to Zhang et al., titled “Determining Cameral Motion;” U.S. Patent Application Publication No. 2007/0008312A1 to Zhou et al., titled “Method for Determining Camera Position from Two-Dimensional Images that form a Panorama;” International Application No. PCT/US2006/060724 to 3M Innovative Properties Company, titled “Determining Camera Motion;” and Lowe, David G, “Three-Dimensional Object Recognition from Single Two-Dimensional Images,” *Artificial Intelligence*, 31, 3 (Mar. 1987), pp. 355-395.

While the central aperture provides valuable information for positioning purposes (“POISE”), it may cause overcrowding. In one embodiment of the present invention, and as shown in FIG. **5H**, the central aperture **556** with off-axis defocusing apertures **558** arrangement is used in conjunction with a light projector **564** for projecting a predetermined pattern of light **566** onto the surface of an object **561**. The predetermined pattern **566** is defocused through the defocusing apertures **558**, and the amount of defocus in the pattern image **568** is used to determine depth information about the object **561**. A potential drawback of this configuration is that the central aperture will also produce unshifted (non-defocused) images of all the points in the projected pattern, which may interfere with the defocused points produced by the defocusing apertures. By using a dot projection system with a narrow-band light source in conjunction with an optical filter on the central aperture **556** (represented as horizontal lines) for selectively filtering out the wavelength of projected light, the unshifted images produced by the central aperture can be removed. In addition, a conjugate filter on the defocusing apertures **558** (represented by vertical lines that allows only the wavelength of projected light to pass can be used to stop the object’s image from forming through the off-axis defocusing apertures, thus keeping the object image **560** from getting blurred.

Further, when using a plurality of defocusing apertures, if the defocusing apertures are placed asymmetrically with respect to the central aperture, then the images of points will also contain this distinction, and the orientation of the image indicates whether the forming point was ahead of or behind the focal plane of the lens. This technique performs the same function as using a single asymmetrical aperture as previously described.

Finally, while the addition of a central aperture can provide helpful reference information in a system with two defocusing aperture system, there is no limit to its application to systems with three or more defocusing apertures.

### (3.3) Electronic Masked Aperture

Referring to FIG. **6A** and FIG. **6B**, an electronically masked imaging system **600** is shown, including a lens **602**, an aperture plate **604**, a multi-window electronic aperture **606**, a sensor **608**, and a processor **610** in communication with the sensor **608** and aperture plate **604**. Non-limiting examples of suitable aperture plates **604** include a liquid crystal display (LCD) which may be fully synchronized with the sensor **608**. In one aspect, the sensitivity may be controlled by varying the “off-axisness” of the apertures. An illuminated object **614** may be reconstructed by selectively allowing reflected rays **616** to pass through the lens **602** and one of the many windows of the multi-window electronic aperture **606**.

As shown in FIG. **6A**, a first window **612** of the multi-window electronic aperture **606** transmits light **618** and produces a first point **620** detected by the sensor **608**. During the

first exposure, the first open window **612** position information is recorded by the processor **610**.

To obtain a second exposure, a second window of the multi-window electronic aperture **606** is opened. As shown in FIG. 6B, a second window **622** of the multi-window electronic aperture **606** allows light **624** to pass and produces a second point **626** detected by the sensor **608**. During the second exposure, the second open window **622** position information is recorded by the processor **610**. The first point **620** and first open window **612** position information and second point **626** and second position open window **622** position information are then used to match the first point **620** from the first exposure with the information of the second point **626**. (4.0) Pattern Matching by Pattern Projection

If the object of interest is a surface whose shape is to be matched, a predetermined pattern of markers may be projected on the surface and the points in the detected image may be sampled by measuring the relative position of the projected markers. The sensor's allowable upper density limit of imaged dots is the imaging system's limit. Once the points are identified in each view, there is only the question of whether the same point exists in both views. In another aspect, if the volume to be mapped contains a cluster of asymmetrical cells in a volume, then the shape and orientation of the cells can be used as an additional constraint in the inter-view matching, thus reducing the chance that a mismatch can occur. This aspect is referred to as "feature matching."

Referring to FIG. 7A, an illustration of an addressable template pattern **700** suitable for projection onto the surface of the object of interest is shown. The addressable template pattern **700** is projected or physically placed on the target surface and then captured by an imaging system at varying distances (Z) from the object. In one aspect, the addressable template pattern **700** is in the form of a grid pattern with a distinguishable center point **702**.

Referring to FIG. 7B, an illustration of an acquired image **704** taken of a target object using an addressable template is shown. As illustrated, some dots **706**, **708**, **710**, and **712** are missing in the acquired image **704**.

Referring to FIG. 7C, the acquired image **704** with a partial grid **714** is shown. If the addressable-pattern **702** is ordered, a grid pattern **714** with a distinguishable origin can employ a method such as "structured pattern matching" to reduce the number of required viewpoints, or image acquisitions, to two. The addressing algorithm, such as one stored on a computer-readable medium or executed by a processor, processes each aperture's image to find the relative address of each dot in the addressable-pattern **704** according to the template pattern. A non-limiting example of a suitable addressable template pattern **700** is illustrated in FIG. 7A. The addressing algorithm has some tolerance to allow for deformation of the addressable-pattern **704** (See FIG. 7B and FIG. 7C). The deformation of the addressable-pattern **704** is noticeable when contrasted with the original addressable template pattern **700** (See FIG. 7A). Further, the addressing algorithm can also account for missing entities **706**, **708**, **710**, and **712** in the acquired image **704**. Missing information is considered missing when a point on the addressable template pattern **700** does not appear in the addressable-pattern **704**.

A reconstructed illustration of the center sample **716** of FIG. 7C is illustrated in FIG. 7D. The points are reconstructed by calculating the Z for each pair of dots with the same address. Any pair with a missing dot is not reconstructed. (4.1) Pattern Projector (Non-Laser)

Please note that although the term "light" may be used when describing various embodiments of the present invention, the present invention is suitable for use over any portion

of the electromagnetic spectrum, including but not limited to microwaves, infrared radiation, ultraviolet radiation, and X-rays. The use of the term "light" is for exemplary purposes and is not intended to limit the scope of the present invention to the visible portion of the electromagnetic spectrum.

Referring to FIG. 8A, a non-laser pattern projector **800** and imaging system **802** are shown. The non-laser pattern projector **800** comprises a lens **804** identical to the imaging lens **806** of the imaging system **802**. The lens **804** of the non-laser pattern projector **800** is placed at an equivalent distance from the beamsplitter **808** as the lens **806** of the imaging system **802**. This causes the principal rays **810** of the projected points **812** to coincide with the principal rays **814** detected by the sensor **816** of the imaging system **802**. Thus the projected pattern **818** will look as though it does not move in the detected image, even when the distance between the projected point **812** and the focal plane **820** of the imaging lens **806** changes. This makes identifying an addressable-pattern **818** much easier, even if some points (e.g., dots) are missing.

The prerequisite is that the images from each viewpoint are physically separate—this is naturally true in multiple-sensor systems such as photogrammetry, but requires special care with systems like the defocusing concept (multiple apertures on a single lens imaging onto a single sensor).

The projected pattern **818** is produced by passing light **822** through a pattern stencil **824** and projector lens system **826** with a lens **804** substantially identical to the imaging lens **806**.

For single-lens systems, the aperture images must be separate. This can be accomplished with prisms (see FIGS. 8B and 8C) or fiberoptic bundles so that each aperture projects onto a separate sensor, or with a physically masked aperture (see FIGS. 8D and 8E) if the sensor is a color sensor.

Referring to FIG. 8B, a two prism off-set and two-sensor system **828** is shown. The system **828** comprises a first prism **830**, second prism **832**, and a first sensor **834** and second sensor **836** behind a mask and two-slit aperture **838**. The first prism **830** and second prism **832** offset the incoming light **840** and **842** from the two-slit aperture **838** such that light transmitted through the first prism **830** and second prism **832** may be detected by separate sensors **834** and **836**. Such a configuration may be used when the two-slit aperture **838** is used to code information based on the inherent properties of light or the light must be separated as is the case when addressable-pattern techniques are employed. Non-limiting examples of suitable inherent properties include but are not limited to the frequency, frequencies, or polarization of coded transmitted light detected images.

Referring to FIG. 8C, a one silvered offset prism and two-sensor system **844** is shown. The system **844** comprises a silvered prism **846**, a first sensor **848** and second sensor **850** behind a mask and two-slit aperture **852**. The silvered prism **846** offsets the first bundle of incoming light **854** from the two-slit aperture **852** such that light transmitted through the silvered prism **846** may be detected by the first sensor **848**. Alternatively, light **856** which has passed through two-slit aperture **852** may also be detected separately on the second sensor **850**.

Referring to FIG. 8D a three CCD-sensor assembly system **858** is shown. The system **858** comprises a three CCD-sensor **860** behind a mask and two-slit aperture **862**. The CCD-sensor **860** includes a blue sensor **862**, a green sensor **864**, and a red sensor **866**. The system of prisms **868** offsets the first bundle of incoming light **870** from the two-slit aperture **856** such that light transmitted through the prism **868** may be detected by the red sensor **866**. Alternatively, light **872** which has passed through the two-slit aperture **852** may also be detected separately on the green sensor **864**.

FIG. 8E is a narrow-band mirror sensor assembly system 874 is shown. The system 874 comprises a narrow-band mirror 876, located behind a mask and two-slit aperture 878, and a first sensor 880 and second sensor 882. The system narrow-band mirror 876 offsets the first bundle of incoming light 884 from the two-slit aperture 878 such that light transmitted through the narrow-band mirror 876 may be detected by the first sensor 880. Alternatively, light 886 which has passed through the two-slit aperture 878 may be detected separately on the second sensor 882.

#### (4.2) Pattern Projector (Laser)

Any lens can be represented by two "principal planes." The location of the planes is only a function of the lens, and all principal rays (which define the image centerline for a point) behave as if they entered the first principal plane and exited the second principal plane at the axis.

By using measurements of the location of the front principal plane and the field of view, a diffraction grating with the desired pattern can be made and positioned such that the beams from the laser projector coincide with the principal rays of the imaged dots. Thus, the projected pattern will look as though it does not move in the image even when the distance between the projected dot and the focal plane of the imaging lens changes. This makes searching for the addressable-pattern much easier even if some dots are not imaged.

A complex ray trace through a compound lens (where the ray kinks at every air/glass interface) can be mathematically represented as two planes at which the rays kink. Thus, the left image shows the "real" ray trace, and the right image shows the mathematical representation of such lens. The planes are found by taking any chief (also called principal) ray coming into the first glass interface and leaving the last glass interface and extending them to intersect the axis of the lens. The intersection marks the location of the planes.

Thus, one would first do a calibration (by imaging a grid at several Z-distances) and then do a least-squares type fit to find out where those two planes are, and what the field of view angle is. Then, the diffraction grating can be customized to match the field of view angle, and put at the same distance from the beam-splitter as the first principal plane. Therefore, the laser beams will follow the exact path of the principal rays.

In operation, as an object gets closer to a lens, it appears larger in the image. This means that the edges of the object move laterally on the image. The same would be true of any pattern projected in front of the camera onto a surface. By making the rays match exactly as in the aspect depicted in FIG. 9, none of the points ever move laterally, regardless of their Z-position.

Now, if a two-hole aperture mask is added, the corresponding dots still move apart from each other (the dots (images) are formed by the marginal (outer rays). However, since the principal ray is not moving laterally, the centroid of the corresponding "match shape" will not move laterally. Conceivably, once the distinguishable dot of the addressable-pattern is located, the centroid of that match can be found. Knowing that the pattern is never expanding laterally, it is known where the centroid of every other point on the pattern should be, which should aid in "addressing" the points.

This is different than the traditional addressable-pattern search, where the points are all moving relative to each other, so that if there's too much of a surface Z-change, the pattern may not be reconstructible.

Referring to FIG. 9, a laser pattern projector system 900 and imaging system 902 are shown. The laser pattern projector system 900 comprises a laser projector 904 and a filtering mask 906. The filtering mask 906 selectively passes light

from the projector 904 onto the fifty percent beam splitter 908. The laser projector 904 and a filtering mask 906 are in-line with the beamsplitter 908 which causes the principal rays 910 of the projected points 912 to coincide with the principal rays 914 detected by the sensor 916 of the imaging system 902. Thus the projected pattern 918 will look as though it does not move in the detected image, even when the distance between the projected point 912 and the focal plane 920 of the imaging lens 906 changes. This makes identifying an addressable-pattern 918 much easier, even if some points (e.g., dots) are missing.

#### (5.0) Imaging Methods

Referring to FIG. 10, a flow chart depicting the steps of acquiring and processing images to develop a two dimensional or three dimensional representation of the surface of an object is shown. Any single-lens device may be built or modified to include an imaging lens, an aperture configured to generate distinguishable images, a sensor, and a processor.

The imaging process begins by illuminating the surface of the object 1000. The surface may be illuminated by the imaging system or a suitable external lighting source. Light is reflected off of the surface of the object and transmitted through the aperture 1010. The aperture may be placed in the plane of the imaging lens, in front of the imaging lens, behind the imaging lens, may be applied at an aperture plane of the imaging lens when accessible, or made accessible via a relay lens system.

As the light travels past the aperture, the aperture may be used in a number of ways to code information received by the sensor. Non-limiting examples of suitable methods by which light may be coded in order to produce distinguishable images 1020 on the sensor include but are not limited to: filtering transmitted light according to light characteristics (such as filtering by wavelength or polarization), transmitting light as a function of time such that the distinguishable images are allowed to pass through the aperture as a function of time; or physically altering the shape of the aperture to comprise a series of different shapes from which transmitted light through the aperture produces distinguishable shape-based images.

An act which aids the system in determining whether or not to acquire additional images 1030 can also be implemented. The act may further be augmented to weigh the suitability of an acquired image. For example, an image detected by a sensor which suffered from excess movement during the exposure may be discarded by the algorithm. In this case, the last acquired image is discarded and the process is re-acquired with the illumination of the object 1000. In another aspect, the received image may be suitable for processing; however, more image acquisition images are needed 1030. In this case, a further decision can be added to further augment the algorithm, an example of which would be to add a decision to determine whether or not the viewpoint of the imaging system should be adjusted 1040. If the position of the imaging device or the desired area of the object needs to be shifted, either the imaging system or the target object may be altered to adjust the viewpoint 1050.

Once all or at least some of the images have been acquired, the relationship amongst points, or point information, within each image is used to calculate or determine the relative or absolute distance information for each point 1060. Once the distance information is known, the information may be fed to an algorithm which uses the distance information to generate a representation (e.g., 3-D mapping) of the object 1070.

#### (6.0) Image Matching

For large objects or applications which require multiple exposure acquisitions, image matching provides a method by which related image acquisitions may be tied together to

recreate an object surface. Although not required to recreate the target object, when the position of the imaging system is known relative to the target object, image matching offers the ability to recreate a target object with exact measurements. In general, image matching, also referred to as digital quilting, is greatly aided by the use of an addressable-pattern template image. In one aspect, the addressable-pattern projector may be physically tied to the acquisition device. In another aspect, the addressable-pattern projector may move independently of the device, but in such a way that the pattern visible by the device is still addressable.

An imaging device acquires an addressable-pattern template image at an initial position. The addressable-pattern template image typically has a fixed number of points in the X, Y, and Z-planes. The position of the imaging device is then adjusted and a second addressable-pattern template image is acquired at second position. Precautions may be taken such that adjusted positions determined to exceed motion constraints are ignored. The second position, or adjusted position, is related to the initial imaging device position by a six-variable solid translation and rotation. Typically, the adjusted position is related to the initial position by the fact that the image captured at the new position overlaps in part with the first template image and has a substantially similar number of points.

In operation, at least one outer hull is generated by a processor or is manually highlighted by the user. The outer hull encompasses all the points within the addressable-pattern template image and addressable-pattern surface image. Although not always the case, the points outside the addressable-pattern template image outer hull may be disregarded. A plurality of inner hulls of the points in the addressable-pattern surface image is also generated. The inner hull is a function of a maximum acceptable displacement between acquisitions within the intersection of the plurality of hulls, according to the six-variable solid-body translation and rotation. The error may be calculated from the difference between a point on the addressable-pattern surface image and the addressable-pattern template image.

When the hulls have been generated, the addressable-pattern information is processed using a matching algorithm. The matching algorithm is configured to determine the distance between each point on the addressable-pattern surface image and its corresponding point on the addressable-pattern template image. Each of the matched points is then formed from the plurality of inner hulls according to their solid-body translations and merged with rotations to form a high-resolution data set.

When hundreds or possibly thousands of acquisitions have been matched, the well-defined point clouds are merged according to their solid-body translations and rotations. An algorithm that uses the addressable-pattern information may also be adapted to determine whether or not enough matching points exist to recover the features of the target object. When a well-defined point cloud has been developed, the high-resolution point cloud can be used to generate or output a high-resolution surface (nurbs, meshes, etc.) with or without interpolation via standard algorithms or commercial packages, such as Geomagic Studio. Geomagic Studio is produced by Geomagic, located at 3200 East Hwy 54, Cape Fear Building, Suite 300, Research Triangle Park, N.C., 27709 U.S.A.

The fit is considered satisfactory if the total error is below some threshold which is a function of the precision of the device. Once this is done, a second acquisition at the adjusted position becomes the template and the next acquisition becomes the surface matched to it. The robustness of addressable-pattern information in the matching algorithm allows

for the matching of small set to small set, without interpolating the surface shape until enough acquisitions are available.

FIG. 11 is a flow chart depicting the use of an addressable-pattern to aide in image reconstruction. The use of an addressable-pattern during surface feature acquisition is one way of bypassing the correspondence search employed in a separable-viewpoint three-dimensional imaging system.

After the starting process 1100 begins with the acquisition of a number of images, each of the images containing (being illuminated with) an addressable-pattern 1102. Each image is typically taken from a different viewpoint, although the addressable-pattern is static with respect to the contours of the object's surface. Each of the plurality of images comprises at least a portion of the addressable-pattern information and at least one point represents at least one aspect of the target object. It will be appreciated by one of skill in the art that an object may include a variety of points on the object. Each point may provide important information with respect to the eventual reconstruction of the object.

An address is assigned to each point in the image in an addressing act 1110. In general, the addressable-pattern provides a sequence or series of plots on the object which may be referenced to assist in the addressing act 1110. Importantly, the addressable-pattern need not be symmetrical or contain a regular sequence of markers or images. Non-limiting examples of suitable addressable-pattern information may include a color sequence pattern, a pattern comprising differently shaped object, a position sequence pattern, distinguishable object features or object landmarks, or any combination thereof. The addressable-pattern image may be placed on the surface of the object in a variety of ways. Non-limiting examples of suitable methods include: projecting the addressable-pattern image onto the surface of the object; physically placing an addressable-pattern image onto the surface of the object; and using the features inherent to the object being imaged as a source.

An act which aides the system in determining whether or not to acquire additional images 1120 can also be implemented. This act may further be augmented to weigh the suitability of an acquired image. For example, an image detected by a sensor which suffered from excess movement during the exposure may be discarded by the algorithm. In this case, the last acquired image would be discarded and the process would be repeated with the illumination of the object 1102. In another aspect, the received image with an addressable-pattern may be suitable for processing; however, more images are needed to reconstruct the object. In this instance, a further decision process can be added to further augment the algorithm, an example of which would be to add a decision to determine whether or not the viewpoint of the imaging system should be adjusted 1130. If the position of the imaging device or the desired area of the object needs to be shifted, either the imaging system or the target object may be altered to adjust the viewpoint 1140.

Once all or at least some of the images have been acquired, the relationship amongst points, or point information, within each image is used to calculate or determine the relative or absolute distance information for each point, which is stored as an addressed list. Once the distance information is known, the information may be fed to an algorithm which uses the distance information to generate a representation of the object 1160.

The drawings and the associated descriptions are provided to illustrate embodiments of the invention and not to limit the scope of the invention. Reference in the specification to "one embodiment" or "an embodiment" is intended to indicate that a particular feature, structure, or characteristic described in



connection with the embodiment is included in at least an embodiment of the invention. The appearances of the phrase “in one embodiment” or “an embodiment” in various places in the specification are not necessarily all referring to the same embodiment.

As used in this disclosure, except where the context requires otherwise, the term “comprise” and variations of the term, such as “comprising,” “comprises” and “comprised” are not intended to exclude other additives, components, integers or steps.

Also, it is noted that the embodiments are disclosed as a process that is depicted as a flowchart, a flow diagram, a structure diagram, or a block diagram. Although a flowchart may disclose various steps of the operations as a sequential process, many of the operations can be performed in parallel or concurrently. The steps shown are not intended to be limiting nor are they intended to indicate that each step depicted is essential to the method, but instead are exemplary steps only.

In the foregoing specification, the invention has been described with reference to specific embodiments thereof. It will, however, be evident that various modifications and changes may be made thereto without departing from the broader spirit and scope of the invention. The specification and drawing are, accordingly, to be regarded in an illustrative rather than a restrictive sense. It should be appreciated that the present invention should not be construed as limited by such embodiments.

From the foregoing description, it will be apparent that the present invention has a number of advantages, some of which have been described herein, and others of which are inherent in the embodiments of the invention described or claimed herein. Also, it will be understood that modifications can be made to the device, apparatus and method described herein without departing from the teachings of subject matter described herein. As such, the invention is not to be limited to the described embodiments except as required by the appended claims.

What is claimed is:

1. A device for three-dimensional (3-D) imaging comprising:

- a lens;
- a substantially oblong aperture obstructing the lens, said oblong aperture having an oblong shape;
- a sensor operable for capturing electromagnetic radiation transmitted from an object through the lens and the substantially oblong aperture; and
- a processor communicatively connected with the sensor for processing the sensor information and producing a 3-D image of the object based on a distance between edges of said oblong shape determined by said sensor.

2. The device of claim 1, where the substantially oblong aperture comprises an asymmetric shape, which is asymmetric along an axis between said edges.

3. The device of claim 2, where the oblong aperture is rotatable, whereby an orientation of an observed pattern relative to the oblong aperture is varied with time thereby minimizing ambiguity generated by image overlap.

4. The device of claim 3, further comprising projection system configured to project a predetermined pattern of elec-

tromagnetic radiation onto a surface of the object thereby allowing for mapping of unmarked surfaces in three dimensions.

5. The device of claim 4, where the sensor comprises rows and columns of pixels, the substantially oblong aperture has a major axis and a minor axis, and where the axes are aligned with the rows and columns of the sensor.

6. The device of claim 5, further comprising a projector which projects a line onto a surface of the object, such that the line is at a substantially right angle to the substantially oblong aperture.

7. The device of claim 1, where the oblong aperture is rotatable, whereby an orientation of an observed pattern relative to the oblong aperture is varied with time thereby minimizing ambiguity generated by image overlap.

8. The device of claim 1, further comprising projection system configured to project a predetermined pattern of electromagnetic radiation onto a surface of the object thereby allowing for mapping of unmarked surfaces in three dimensions.

9. The device of claim 1, where the sensor comprises rows and columns of pixels, the substantially oblong aperture has a major axis and a minor axis, and where the axes are aligned with the rows and columns of the sensor.

10. The device of claim 1, further comprising a projector which projects a line onto a surface of the object, such that the line is at a substantially right angle to the substantially oblong aperture.

11. The device of claim 1, where the oblong aperture has rounded edges at ends of the oblong shape.

12. A method for three-dimensional (3-D) imaging of an object, comprising acts of:

- capturing electromagnetic radiation transmitted off of an object and through a lens and a substantially oblong aperture with a sensor, said oblong aperture having an oblong shape; and
- processing defocused information from the sensor indicative of a distance between edges of the oblong shape to produce a 3-D image representative of the object.

13. The method of claim 12, where the substantially oblong aperture comprises an asymmetric shape, which is asymmetric along an axis between said edges.

14. The method of claim 12, further comprising an act of rotating the substantially oblong aperture, whereby an orientation of an observed pattern relative to the oblong aperture is varied with time thereby minimizing ambiguity generated by image overlap.

15. The method of claim 12, further comprising an act of projecting a predetermined pattern of electromagnetic radiation onto a surface of the object thereby allowing for mapping of unmarked surfaces in three dimensions.

16. The method of claim 12, where the sensor comprises rows and columns of pixels, the substantially oblong aperture has a major axis and a minor axis, and where the axes are aligned with the rows and columns of the sensor.

17. The method of claim 12, further comprising an act of projecting a line onto a surface of the object, such that the line is at a substantially right angle to the substantially oblong aperture.

18. The device of claim 12, where the oblong aperture has rounded edges at ends of the oblong shape.